



OG 2023-Up Touring CVO Lower Triple Tree kit Installation-1.0

Please refer to your bike service manual for additional guidance.

The installation of this lower triple tree requires the separate purchase of OG 2023-Up Touring CVO Top Triple Tree

1. Disconnect Wiring:
 - a. Disconnect left and right handlebar switch connectors.
 - b. Disconnect the throttle sensor connector.
 - c. If equipped, disconnect heated hand grip connectors.

*For a smoother installation, keep your hand controls and switches installed on the handlebar.

2. Remove the front wheel, fender and suspension.
3. Separate the handlebar from the top triple tree.
4. Remove the OEM or OG top triple tree.
5. Remove the OEM lower triple tree and fork stem.
6. Slide the **OG Fork Stem** into the **OG Lower Triple Tree**. Refer to the attached diagram. Do not torque the Fork Stem pinch bolt yet.
7. Install lower neck bearing on the **OG Fork Stem**.
8. Install the upper neck bearing & slide the **OG Fork Stem/Lower Triple Tree** assembly into the neck.
9. Thread the OG Stem Nut on the OG Fork Stem. Torque the Stem Nut until the bearings are properly seated.
10. Torque the lower Fork Stem pinch bolt to: **30 ft-lbs**
11. Install the OG Top Triple Tree. Please refer to the OG 2023-Up Touring CVO Top Triple Tree installation instructions for additional guidance.
12. Do not torque any pinch bolt on the Top Triple Tree yet.
13. Install the front suspension, fender and wheel.
14. Use the supplied P-Clamp to attach the front brake line to the OG Lower Tree.
15. Install your handlebar and risers on the top triple tree.
16. Adjust the torque on the stem nut. **Please refer to your bike service manual for additional guidance.**
17. Torque all the pinch bolt on the lower tree and triple tree. **Refer to the attached diagram** for the torque values.
18. Reconnect the wiring.



OG 2023-Up Touring CVO Lower Triple Tree kit Installation-1.0

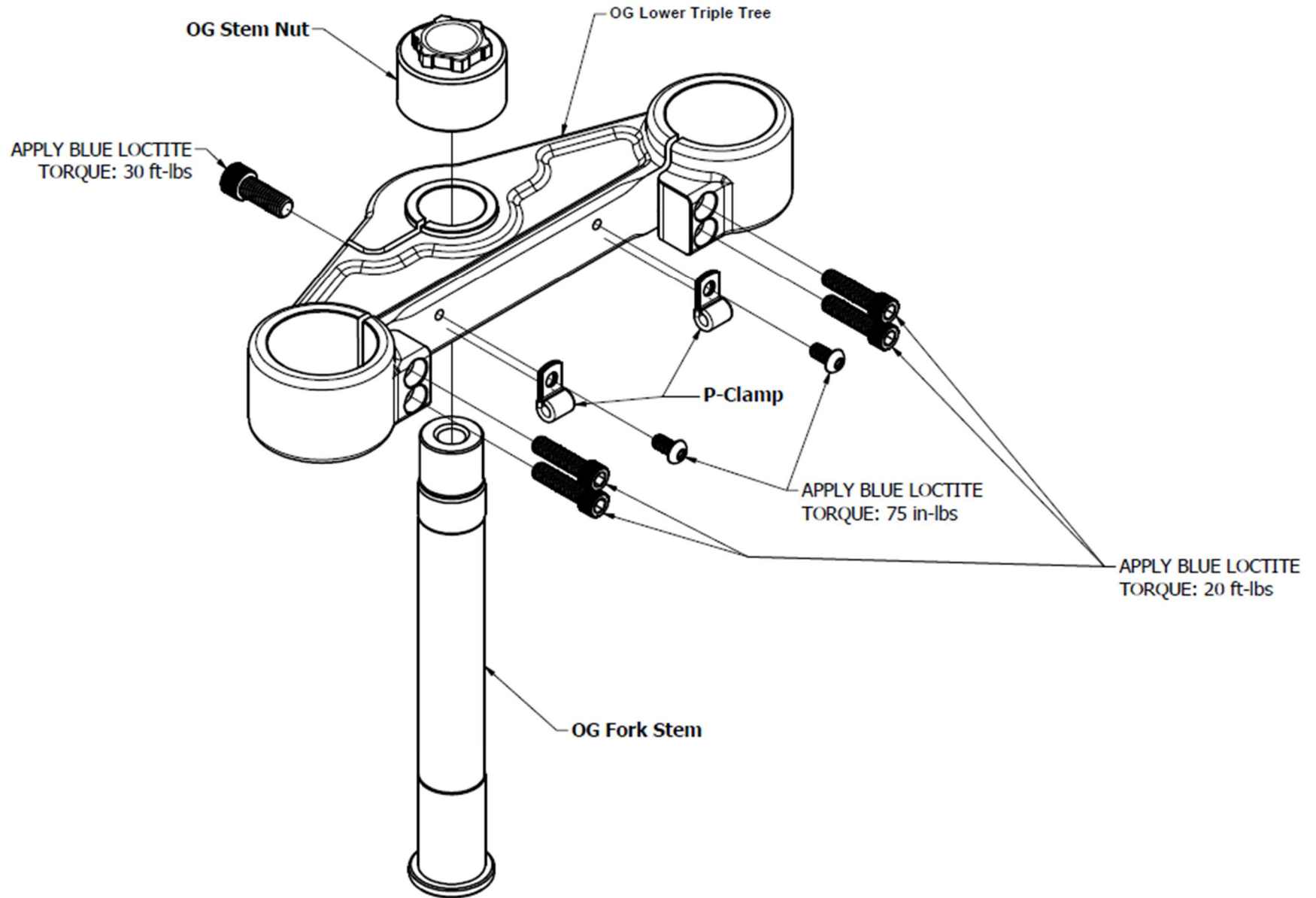

Need help? info@originalgaragemoto.com