



OG 2023-Up Touring CVO Triple Trees kit Installation-1.0

Please refer to your bike service manual for additional guidance.

1. Disassemble:
 - a. Remove the OEM triple tree cover
2. Disconnect Wiring:
 - a. Disconnect the left and right handlebar switch connectors.
 - b. Disconnect the throttle sensor connector.
 - c. Disconnect the upper fork bracket ground connector.
 - d. If equipped, disconnect heated hand grip connectors.

*For a smoother installation, keep your hand controls and switches installed on the handlebar.

3. Remove the OEM top triple tree.
4. Separate the handlebar from the top triple tree.
5. Remove the OEM lower triple tree and fork stem.
6. Slide the **OG Fork Stem** into the **OG Lower Triple Tree**. Refer to the attached diagram. Do not torque the Fork Stem pinch bolt yet.
7. Install the lower neck bearing on the **OG Fork Stem**.
8. Install the upper neck bearing & slide the **OG Fork Stem/Lower Triple Tree** assembly into the neck.
9. Thread the OG Stem Nut on the OG Fork Stem. Torque the Stem Nut until the bearings are properly seated.
10. Torque the lower Fork Stem pinch bolt to: **30 ft-lbs**
11. Install Touring Riser bushing. We strongly recommend polyurethane bushings for risers lower than 9" and solid bushings, for risers higher than 9".
12. Install your handlebar and risers on the top triple tree.
13. Install your new OG Top Triple Tree. Refer to the attached diagram for torque specifications and parts assembly. **DO NOT TIGHTEN THE STEERING STEM AND FORK PINCH BOLT AT THIS POINT.**
14. The riser mounting blocks can be flipped for a 2" pullback setup. 1" Pullback Mounting Blocks are available and sold separately. FL models with batwing fairing will need to run +2" pullback risers position in order to clear the inner fairing.
15. Reconnect the wiring.
16. Carefully route your wires using the supplied P-clamps.
17. Lift the front wheel and adjust the tension on the steering stem.
 - a. Turn the handlebar completely to the left.
 - b. Let go of the handlebar
 - c. It should:
 - i. Pass the neutral point and go right (1)
 - ii. Go left and pass the neutral point (2)
 - iii. Go back and stay at the neutral point (3)
 - d. Add or remove tension on the steering stem bolt depending on the results

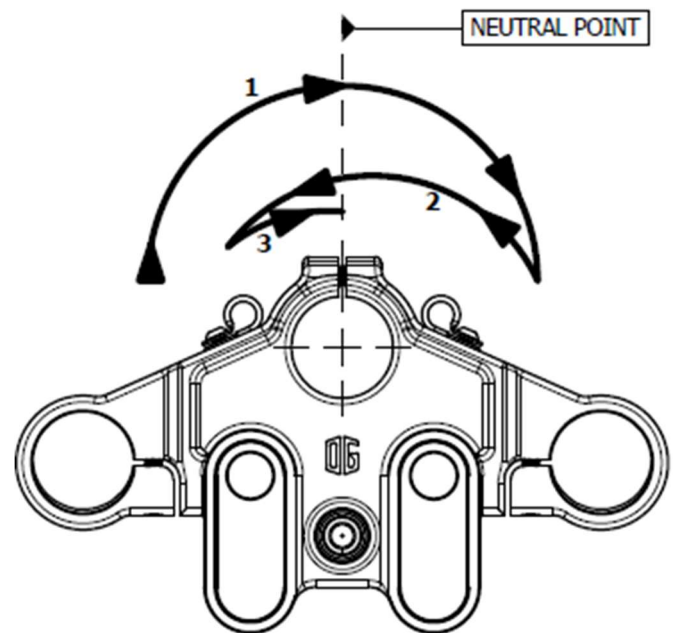



OG 2023-Up Touring CVO Triple Trees kit Installation-1.0

18. Torque the **steering stem pinch and fork pinch bolts**. Refer to the attached diagram for torque specifications and parts assembly.

OG 2023-Up Touring CVO Triple Trees kit H-AC-136-XX

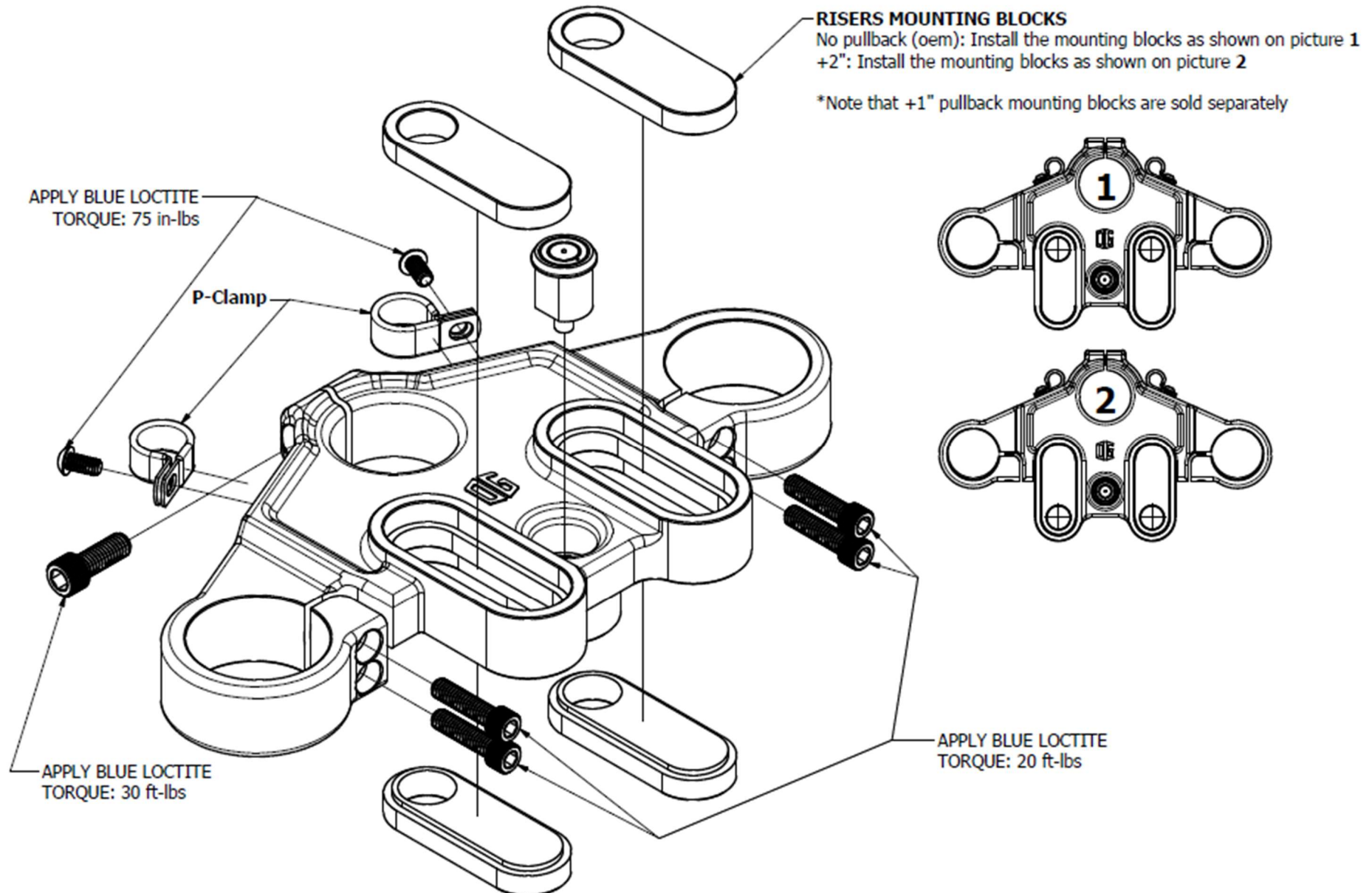

OG 2023-Up Touring CVO Triple Trees kit H-AC-136-XX

