



## OG 2024-Up Touring Drop 1" Top Triple Tree Installation-1.0

Please refer to your bike service manual for additional guidance.

1. Remove the OEM triple tree cover
2. Disconnect Wiring:
  - a. Disconnect left and right handlebar switch connectors.
  - b. Disconnect the throttle sensor connector.
  - c. Disconnect the upper fork bracket ground connector.
  - d. If equipped, disconnect heated hand grip connectors.

\*For a smoother installation, keep your hand controls and switches installed on the handlebar.

3. Separate the handlebar from the top triple tree.
4. Remove the OEM top triple tree.
5. At this point, consider inspecting, cleaning and greasing your neck bearing.
6. Apply blue Loctite on the OEM steering stem bolt.
7. Install the **2024-up Top Triple Tree stem adapter & Cap**. Hand tight the OEM fork stem screw and make sure that the bearings are properly seating. Make sure that the gap on the 2024-up Top Triple Tree stem adapter is toward the front of the bike.
8. Install your new OG Top Triple Tree. **Refer to the attached diagram** for torque specifications and parts assembly. **DO NOT TIGHT THE STEERING STEM PINCH BOLT AT THIS POINT.**
9. The risers mounting blocks can be flipped for a 2" pullback setup. 1" Pullback Mounting Blocks are available and sold separately. FL models with batwing fairing will need to run +2" pullback risers position in order to clear the inner fairing.
10. Install Touring Risers bushing. We strongly recommend polyurethane bushings for risers lower than 9" and solid bushings for risers higher than 9".
11. Install your handlebar and risers on the top triple tree.
12. Reconnect the wiring.
13. Carefully route your wires using the supplied P-clamps.
14. Lift the front wheel and adjust the tension on the steering stem.
  - a. Turn the handlebar completely to the left.
  - b. Let go of the handlebar
  - c. It should:
    - Pass the neutral point and go right (1)
    - Go left and pass the neutral point (2)
    - Go back and stay at the neutral point (3)
  - d. Add or remove tension on the steering stem bolt depending on the results
14. Torque the steering stem pinch bolt.

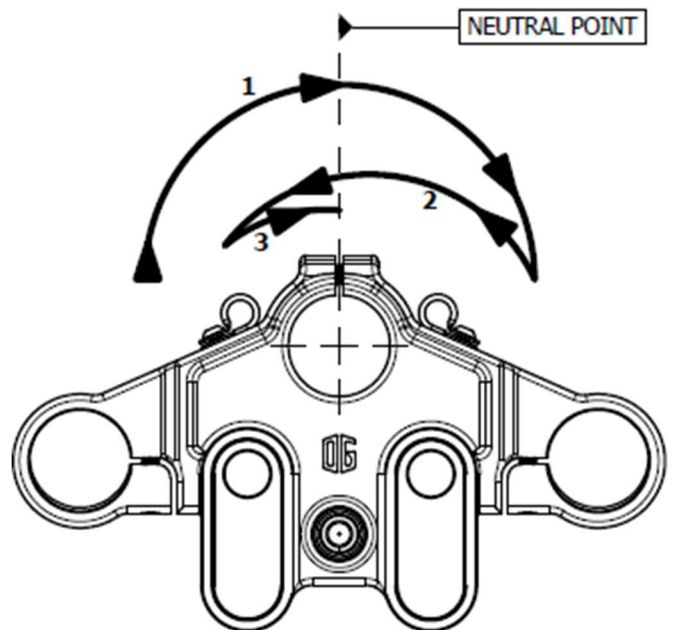



## OG 2024-Up Touring Drop 1" Top Triple Tree Installation-1.0

15. When adjusting the front end height, ensure that the fork tube does not sit below the top of the top triple tree.

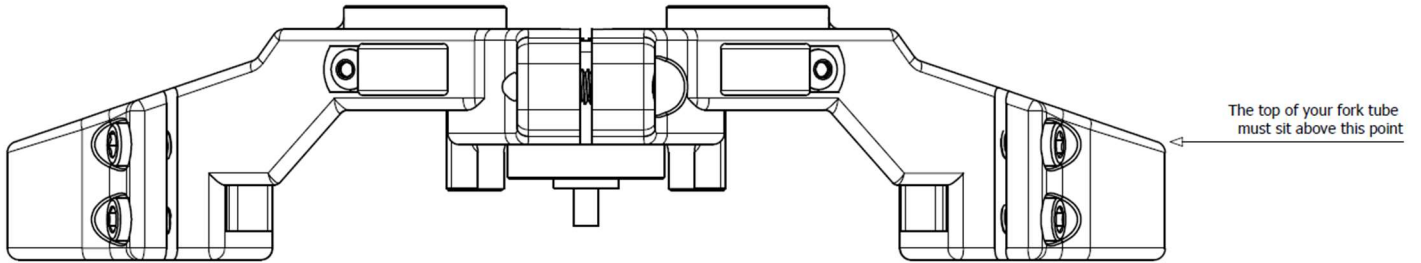

Need help? [info@originalgaragemoto.com](mailto:info@originalgaragemoto.com)

# OG 2024-Up Touring Drop 1" Top Triple Tree H-AC-102-XX

