



# AltRider Skid Plate for BMW R 1250 GS INSTALLATION INSTRUCTIONS

The most up to date instructions can be downloaded from the product page at [altrider.com](http://altrider.com), under the instructions tab.

Dear Rider,  
Thank you for choosing AltRider! Whether a seasoned world adventurer or a first time ADV-Newbie, we welcome you to the AltRider experience. You can install your new product with the utmost confidence. AltRider designs, tests, and manufactures all of its products here in the United States. We are proud to do what we do, and honored to present to you the product of our labors.

Enjoy it, show it off, and most of all, RIDE IT!

Venture On,  
Jeremy LeBreton



## AltRider Skid Plate for BMW R1250 GS/ GSA

Package Contents:  
- Skid Plate  
- instructions  
- hardware kit

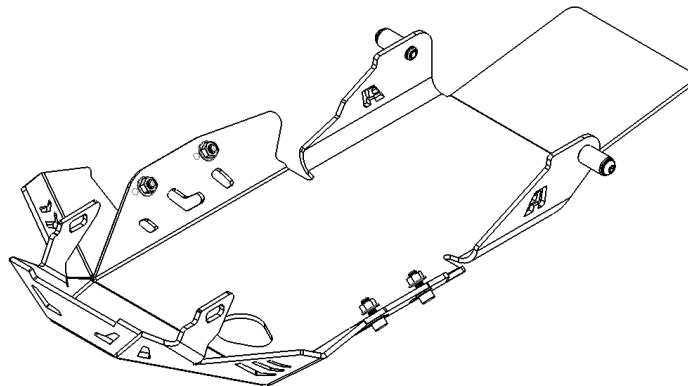

## AltRider LLC

mailing: 4000 Aurora Ave N Ste 100  
Seattle, WA 98103 USA  
phone: 206-922-3618  
email: [info@altrider.com](mailto:info@altrider.com)  
web: [www.altrider.com](http://www.altrider.com)

REV  
MADE IN THE USA



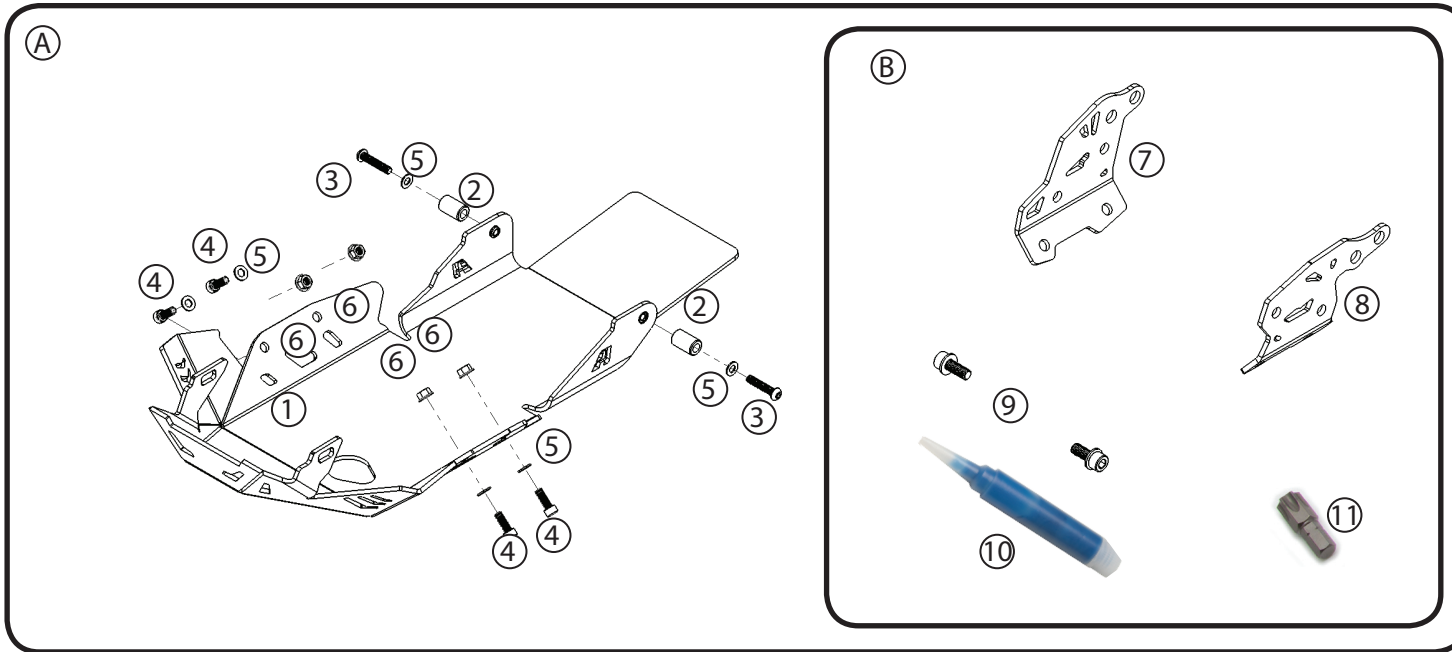

Kit:

- Ⓐ **Skid Plate Contents**
- ① Skid plate
- ② (2) Center stand pins
- ③ (2) M8 x 40mm button head bolt
- ④ (4) M8 x 20 mm SH cap bolts
- ⑤ (6) M8 washers
- ⑥ (4) M8 Nuts
  
- Ⓑ **Bracket Contents**
- ⑦ Right bracket
- ⑧ Left bracket
- ⑨ (2) M10 x 25 bolts
- ⑩ Thread locker
- ⑪ T50 torx driver

Recommended tools:

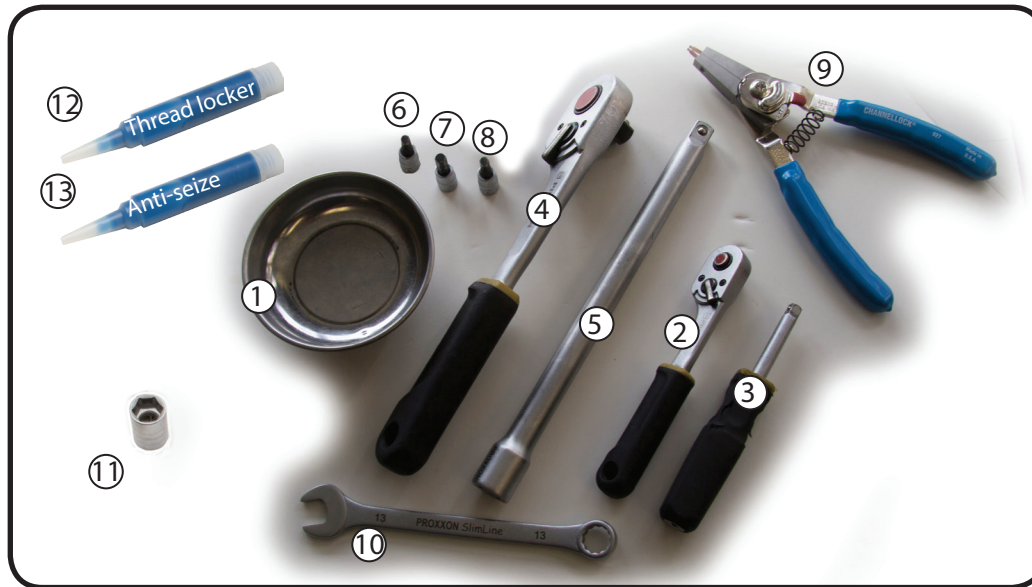

- ① Hardware tray
- ② 1/4" ratchet
- ③ 1/4" driver
- ④ 1/2" driver
- ⑤ 1/2" extension
- ⑥ 5mm allen
- ⑦ 6mm allen
- ⑧ 8mm allen
- ⑨ Snap ring pliers
- ⑩ 13mm wrench & socket
- ⑪ 8mm socket for use with T50 torx driver
- ⑫ Thread locker
- ⑬ Anti-seize



## ! If installing on the Adventure model

**TIP:** When installing the skid plate in conjunction with OEM crash bars, loosen All (4) M10 bolts connecting the OEM lower and upper crash bars. If you have auxiliary lights, you may need to clock or remove the auxiliary light mounts to reach these bolts. Remember to tighten all crash bar fasteners after install of the skid plate is complete.

**AltRider Crash Bars:** If you also purchased AltRider crash bars install the skid plate first, reference crash bar instructions. If you already have AltRider crash bars installed remove the M10 bolts for the front lower spars on both sides and loosen the three remaining bolts on both sides. Then skip to step #3.



- ① Place bike on center stand. Remove OEM skid plate and any brackets. Using a T50 Torx driver remove the (2) OEM engine bolts from each side, keep them.

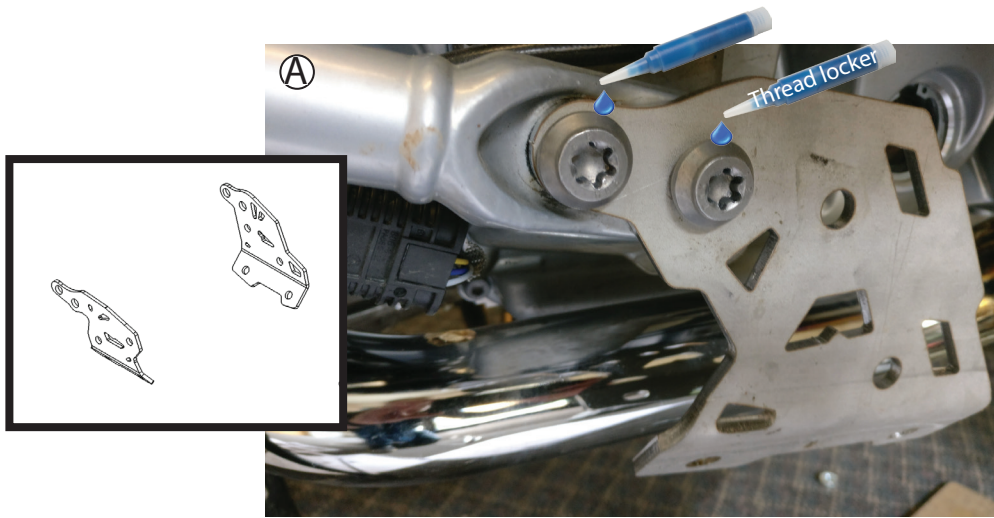

- ② Starting with the right side install the brackets with (2) OEM M10 Torx bolts and apply thread locker. Get all fasteners started but do not tighten yet. Repeat on the left side. See diagram above for reference. TIP: take your time getting the frame aligned with holes in engine mounts. Note: If the holes are not aligned have a helper try lifting the rear of the bike slightly to help.



- Adventure Model:** (b) If you are using the BMW bars, follow steps in 2(a), when fastening OEM M10 Torx place BMW bars over the AltRider brackets.

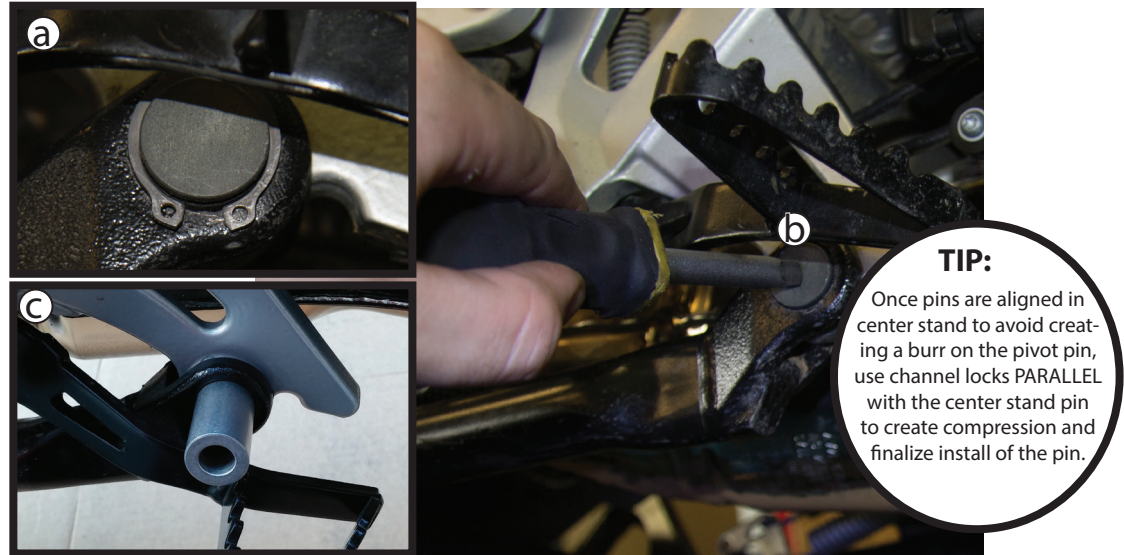

- ③ Place the bike on its side stand. Using your hand compress the rear brake caliper so you can freely move the rear brake lever down.

**TIP:**

Once pins are aligned in center stand to avoid creating a burr on the pivot pin, use channel locks PARALLEL with the center stand pin to create compression and finalize install of the pin.

- ④ One side at a time and starting on the right side, remove the snap ring (a). Push OEM pin inward a bit with extension to get it started (b). Lube the AltRider aluminum hollow pin with grease, and use it to push the OEM pin out the rest of the way (c). Push AltRider pin completely into place. Repeat for left side.



- ⑤ Adjust pins so they are centered on the frame, with a few millimeters protruding from both the inner and outer side of the center stand pivot.

**TIP:**

Once pins are installed, you can deploy centerstand to help align skid plate.

- ⑥ With bike still on side stand. Apply loctite to each M8 x 45mm long Button Head bolt. Install bolt with washer through each hollow center stand pin and into the threaded insert in the skid plate. Do not fully tighten yet.



With back of skid plate loosely attached align front of skid plate with front mounts at the bottom of the engine. Using (2) M10 x x25 socket head cap bolts included with the brackets, apply thread locker, and (2) M10 washers (one for each side), do not fully tighten.

⑦

**AltRider Crash Bars:** If you are also installing the AltRider crash bars leave these bolts and the 4 bolts holding the brackets loose when finishing the skid plate.

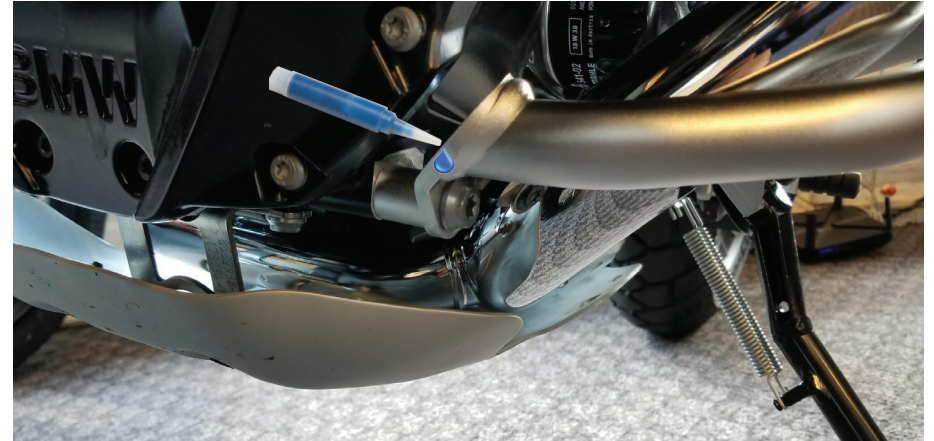

**BMW Crash Bars:** The AltRider skid plate goes in underneath the spacer and crash bar shown here. Use BMW bolt and spacer when attaching the AltRider skid plate. Apply thread locker.



⑧

Fasten all (4) M8 socket head cap bolts and M8 washers on bolt side, tighten with (4) M8 lock nuts. Use thread locker. Torque to 19nm.



⑨

Check brake pedal action for clearance to bolt head. Push pin in further or adjust lever if more clearance is needed.

Return to bracket bolts listed in step #2 and torque the M10's to 55nm. Tighten each M8 bolt to 10nm of torque from step 6. Tighten M10 bolts from step 8 to 38nm. Ride for 100 - 500 miles and check inspect all fasteners for correct torque rating.

## CONGRATULATIONS!

**You've completed your installation. If at any point you have questions about your installation or have any feed back for us, we'd love to hear it. A downloadable version of these instructions can be found at our web site. [www.AltRider.com](http://www.AltRider.com)**

**After 5 hours of riding, or 100 miles, check all the fasteners on the assembly to ensure they are tightened to spec.**

### Global Office:

**email: info@AltRider.com**  
**phone: +1 206-922-3618**  
**address: 4000 Aurora Ave N**  
**Ste 100**  
**Seattle, WA 98103**

### Europe Office:

**email: info@AltRider.eu**  
**address: Spectrumlaan 31**  
**2665 NM Bleiswijk**  
**Netherlands**

#### TERMS OF USE, WARRANTY AND LIABILITY WAIVER

AltRider LLC, a Washington company, having its principal place of business in Seattle, WA ("AltRider") offers its motorcycle accessories (the "Product") with the terms, conditions and notices as follows:

##### Terms of Use

This Product is offered to you conditioned upon your acceptance without modification of the terms, conditions, and notices contained herein. Installation and/or use of this product implies acceptance of all such terms, conditions, and notices. If you do not agree to these terms, do not buy the Product. If you have already bought the Product and do not agree to these terms, return this Product promptly including the packaging and all written materials, to AltRider.

##### Limitation of Liability and Warranty Disclaimer

You may return your merchandise for a full refund or exchange, less any original or return shipping fees under these conditions:

1. Only if the merchandise is in 100% factory condition. Original manufacturer's packaging and same condition as sold – original boxes, packaging material, instructions, documentation, parts, and attached tags.
2. Only unused, unscratched, uninstalled, undamaged merchandise will be accepted. Do not install equipment until you are sure you want to keep it. Package items carefully in protective materials before returning them. Never ship an item in its original manufacturers packaging – it will arrive damaged. Please use a postal box or other adequate packaging to ensure your return or exchange is not damaged on the way back to AltRider.com.

To read more about our exchanges and returns policy, on the web, navigate to <http://www.altrider.com/info/exchangesAndReturns>

Excepting the warranties stated in the preceding paragraph, AltRider hereby disclaims all other warranties and conditions with regard to the Product including all implied warranties and conditions of merchantability and fitness for a particular purpose. There are no warranties which extend beyond the description on the face hereof. AltRider does not warrant against damages or defects arising out of use or installation of the Product. Installation instructions are provided for your convenience. AltRider is not responsible for any damages arising out of the installation, improper or otherwise, of the Product. No warranty of any kind, expressed or implied, is made regarding the safety of this Product.

To the extent allowed by law, AltRider shall not be held liable for any direct, indirect, punitive, incidental, special or consequential damages arising out of, or connected with, the use or misuse of this Product. Buyer assumes all risks and liability arising from use of this Product.

##### Entire Agreement

This document states the entire obligation of AltRider with respect to the Product. If any part of this agreement is determined to be void, invalid, unenforceable or illegal, including, but not limited to the warranty disclaimers and liability limitations set forth above, then the remainder of the agreement shall remain in full force and effect.

##### Applicable Law

This agreement is governed by the laws of Washington, USA. You hereby consent to the exclusive jurisdiction and venue of the courts of Washington, USA, in all disputes arising out of or relating to the use of this product.

