

Unlocked

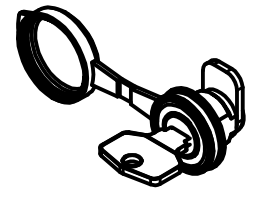

Locked

For lock mechanism type below:

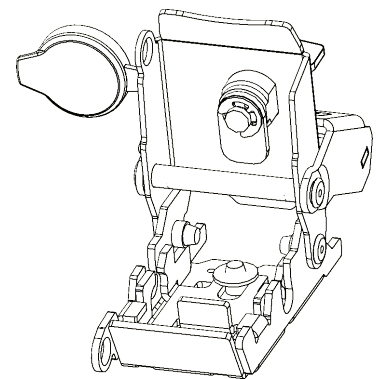
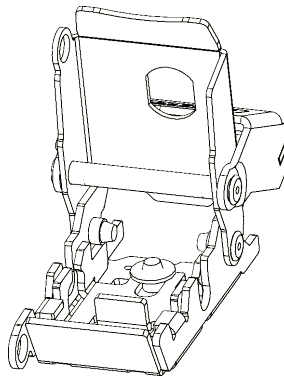
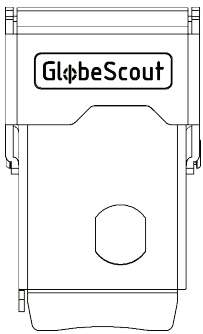

- Turn the key 90° clockwise to locked position
- Place the lock cylinder

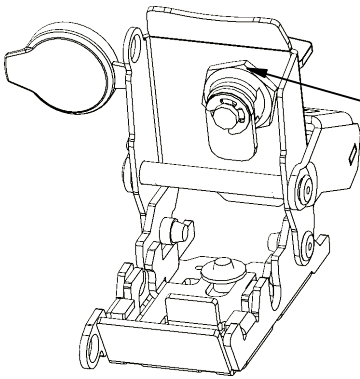

- Apply thread locking fluid
- Tighten with Special Tool #3
- Turn the key 90° counterclockwise to unlocked position

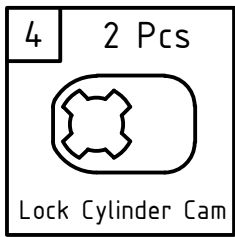

Scale 1:1

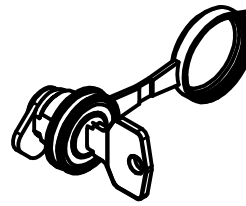

Unlocked

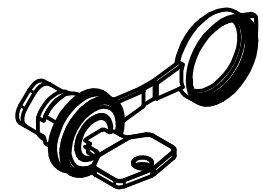

Locked

For lock mechanism type below:

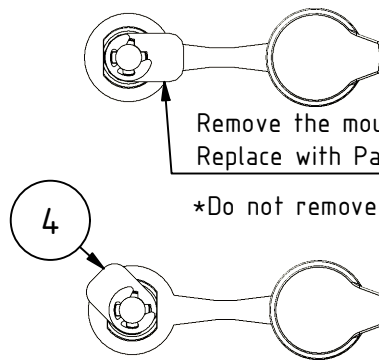
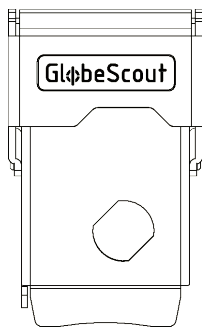

Remove the mounted lock cylinder cam
Replace with Part #4 lock cylinder cam

*Do not remove the key during process

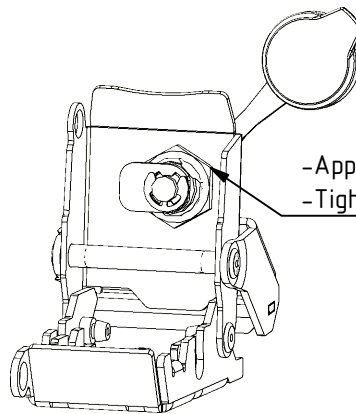
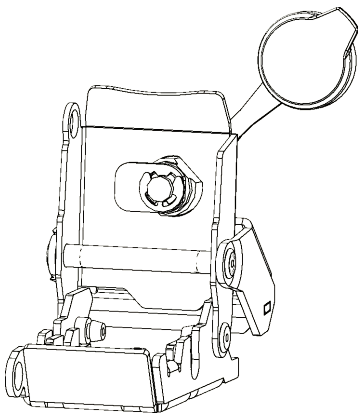

-Apply thread locking fluid
-Tighten the M16 nut #2 with Special Tool #3

- Turn the key 45° clockwise to middle position
- Place the lock cylinder
- Turn the key 45° counterclockwise to unlocked position