

HONDA TALON WINCH MOUNT

Winch Mount

Part # 101750

Kit Components:

Item #	Qty.	Description
1	1	Winch Mount Plate
2	1	Fairlead Mount
3	2	Square Tube Bracket
4	1	Contacter Bracket
5	1	HK-031
6	1	HK-198
6.1	2	M8-1.25 x 60 Hex Flange Bolt
6.2	8	M8-1.25 x 20 Hex Flange Bolt
6.3	8	M8-1.25 Hex Flange Nylock Nut

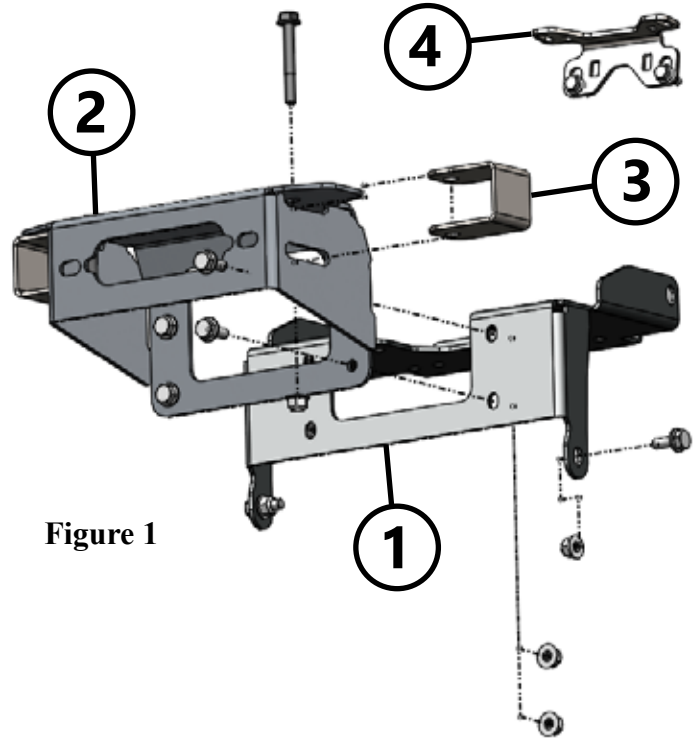
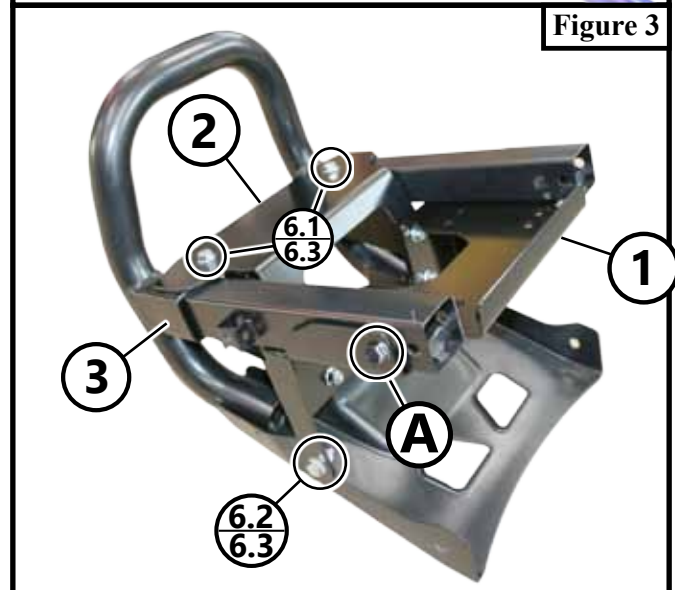
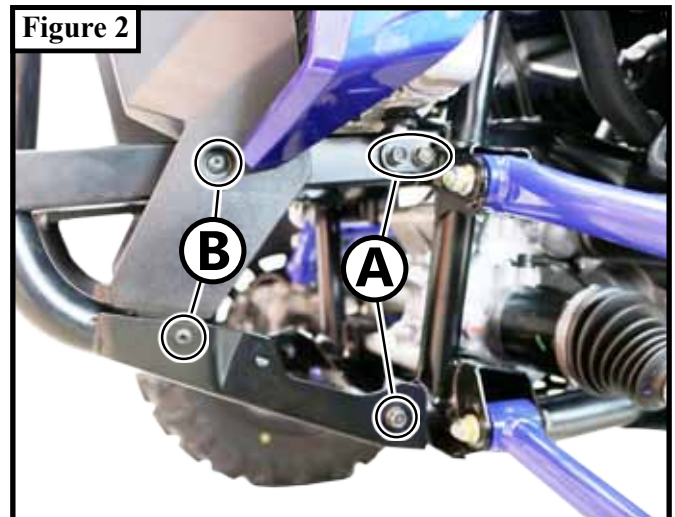

Figure 1

INSTALLATION INSTRUCTIONS:

Note: Make sure all of the hardware needed to complete this mount is in the package. Read through and understand the instructions before installing.

1. Remove front bumper by removing bolts (A) and (B) shown in **Figure 2** on both the passenger and driver side of the vehicle.
2. Set winch mount plate (1) into place and insert one of the top OEM bolts (A) removed in step one through the bumper and the mount to hold the mount in place as shown in **Figure 3**. Bolt bottom of mount to the bumper fascia using M8 bolt (6.2) and M8 nut (6.3) as shown in **Figure 1 & 3**.
3. Set fairlead mount (2) into the bumper and insert the two square tube brackets (3) over the square tube frame on the bumper and into the fairlead bracket as shown in **Figure 1 & 3**. Loosely fasten using M8 bolts (6.1) and M8 nut (6.3)



4. Fasten the winch mount (1) to the fairlead mount (2) using four M8 bolts (6.2) and nuts (6.3) as shown in **Figure 4**. **Note:** be sure that the winch mount (1) is centered with the square frame tube of the bumper before tightening.
5. Mount your winch upside down with the winch motor on the driver side of the vehicle and the clutch on the passenger side as shown in **Figure 5**. **Note:** see **Figure 6** for winch bolt hole locations for standard and wide winches.
6. Reinstall the bumper using the OEM hex flange bolts (A) and the OEM allen head bolts (B) removed from step one as shown in **Figure 7**. **Note:** some bolts may need to be loosened to fit the winch mount and bumper back on to the machine, then tightened once bumper is installed.
7. Tighten all hardware evenly.

Figure 4



Figure 5

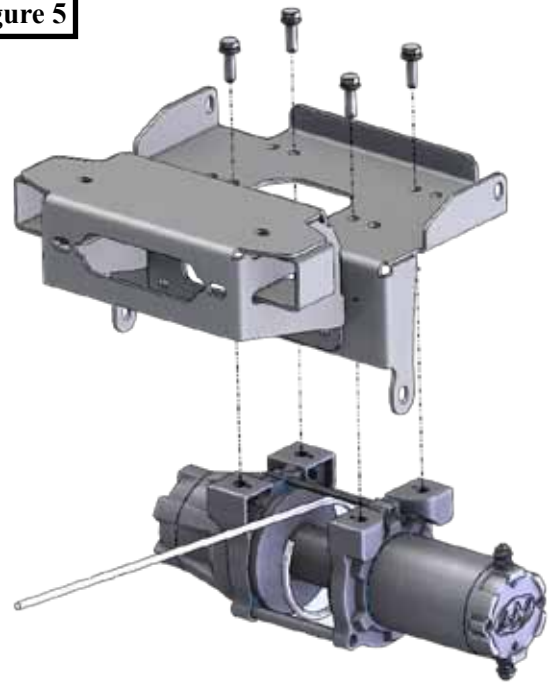

Figure 6

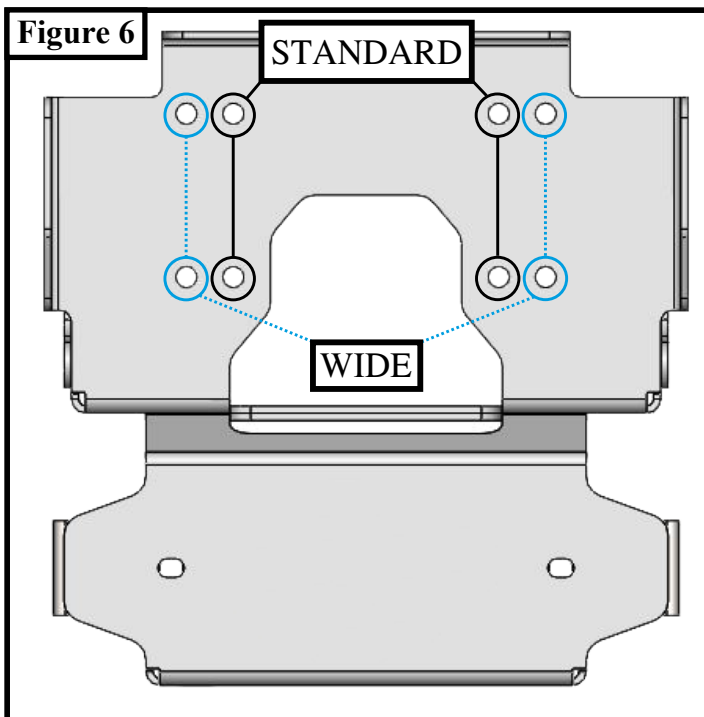
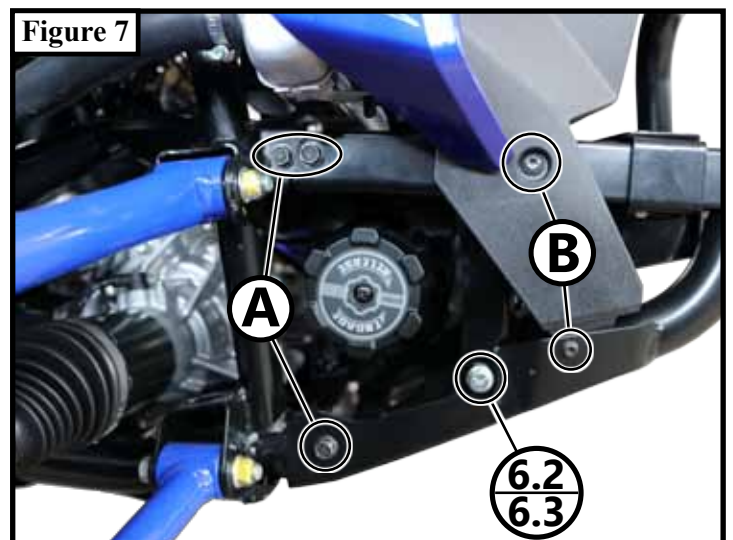

Figure 7



WIRING INSTRUCTIONS

1. Remove the hood and the top plastic cover by removing the plastic push rivets and bolts labeled (C) as shown in **Figure 1**.
2. Bolt the contactor bracket (4) provided with your winch mount to the OEM contactor location as shown in **Figure 2 & 3** using two of the contactor bolts supplied with your winch. **Note:** the holes in the OEM contactor location may need to be drilled out to fit the bolts through. Bolt the contactor supplied with your winch to the contactor bracket (4) as shown in **Figure 3**.
3. Using the pre-ran OEM positive (+) and negative (-) battery cables shown in **Figure 2** wire your contactor and switches per your wiring instructions provided in the winch manual. **Note:** you will need to connect the red positive (+) battery cable to the battery located under the rear driver's side fender as shown in **Figure 4**. The black negative (-) battery cable is already grounded.

Keyed 12V Accessory Wire:

Located near the OEM contactor location is a blue plug attached to the frame tube of the machine with a green and a white/black wire as shown in **Figure 2 & 5**.

-Connect the red positive (+) wire from your rocker switch and/or hand remote to the white/black wire on the OEM plug.

