

# [POWER COMMANDER V]

## FUEL AND IGNITION

**2010-2013 Honda VT1300 models**

Installation Instructions



### PARTS LIST

- 1 Power Commander
- 1 USB Cable
- 1 CD-ROM
- 1 Installation Guide
- 2 Power Commander Decals
- 2 Dynojet Decals
- 2 Velcro
- 1 Alcohol swab
- 1 Posi-tap

**THE IGNITION MUST BE TURNED OFF BEFORE INSTALLATION!**

YOU CAN ALSO DOWNLOAD THE POWER COMMANDER SOFTWARE AND LATEST MAPS FROM OUR WEB SITE AT:  
[www.powercommander.com](http://www.powercommander.com)

**PLEASE READ ALL DIRECTIONS BEFORE STARTING INSTALLATION**

**Dynojet**

2191 Mendenhall Drive North Las Vegas, NV 89081 (800) 992-4993 [www.powercommander.com](http://www.powercommander.com)

# POWER COMMANDER V INPUT ACCESSORY GUIDE

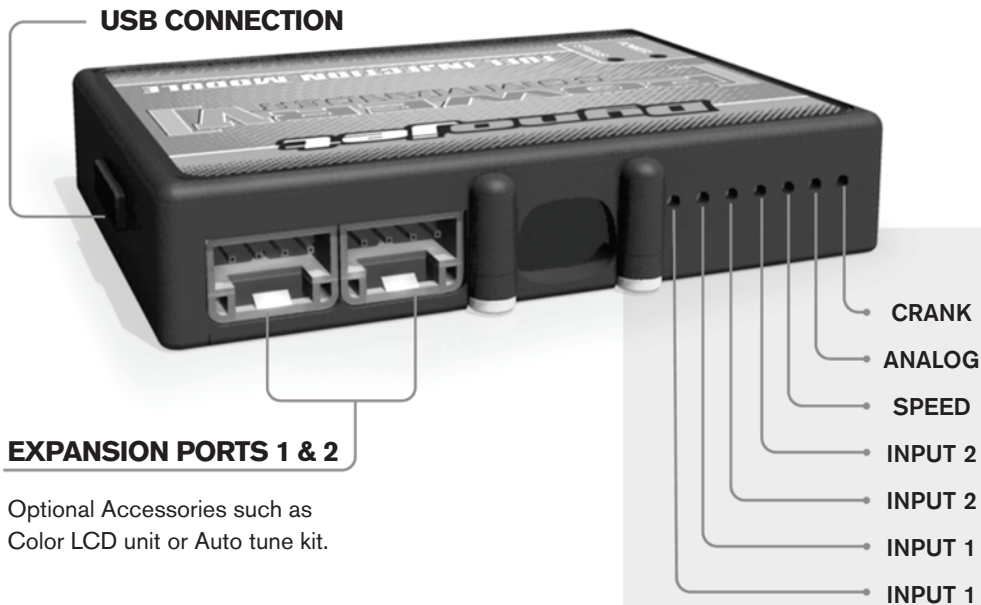

## EXPANSION PORTS 1 & 2

Optional Accessories such as Color LCD unit or Auto tune kit.

## Wire connections:

To input wires into the PCV first remove the rubber plug on the backside of the unit and loosen the screw for the corresponding input. Using a 22-24 gauge wire strip about 10mm from its end. Push the wire into the hole of the PCV until it stops and then tighten the screw. Make sure to reinstall the rubber plug.

NOTE: If you tin the wires with solder it will make inserting them easier.

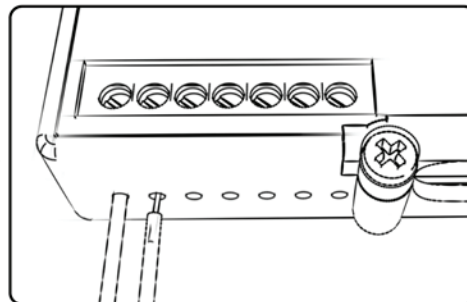

## ACCESSORY INPUTS

### Map -

(Input 1 or 2) The PCV has the ability to hold 2 different base maps. You can switch on the fly between these two base maps when you hook up a switch to the MAP inputs. You can use any open/close type switch. The polarity of the wires is not important. When using the Autotune kit one position will hold a base map and the other position will let you activate the learning mode. When the switch is "CLOSED" Autotune will be activated.

### Shifter-

(Input 1 or 2) These inputs are for use with the Dynojet quickshifter. Insert the wires from the Dynojet quickshifter into the SHIFTER inputs. The polarity of the wires is not important.

### Speed-

If your application has a speed sensor then you can tap into the signal side of the sensor and run a wire into this input. This will allow you to calculate gear position in the Control Center Software. Once gear position is setup you can alter your map based on gear position and setup gear dependent kill times when using a quickshifter.

### Analog-

This input is for a 0-5v signal such as engine temp, boost, etc. Once this input is established you can alter your fuel curve based on this input in the control center software.

### Crank-

Do **NOT** connect anything to this port unless instructed to do so by Dynojet. It is used to transfer crank trigger data from one module to another.



- 1 Remove the seat.
- 2 Remove the left side panel below the drivers seat.
- 3 Remove the fuel tank up.
- 4 Install the PCV to the front side of the battery using the stock rubber strap to secure the unit (Fig. A).
- 5 Route the PCV harness along the main wiring harness on the left side of the bike.

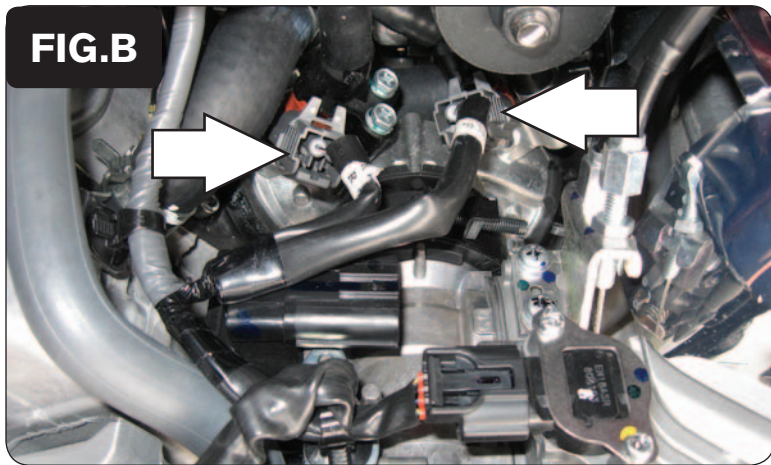

- 6 Unplug the stock wiring harness from each injector (Fig. B).  
*Pay attention to the orientation of the connectors. "F" is front.*

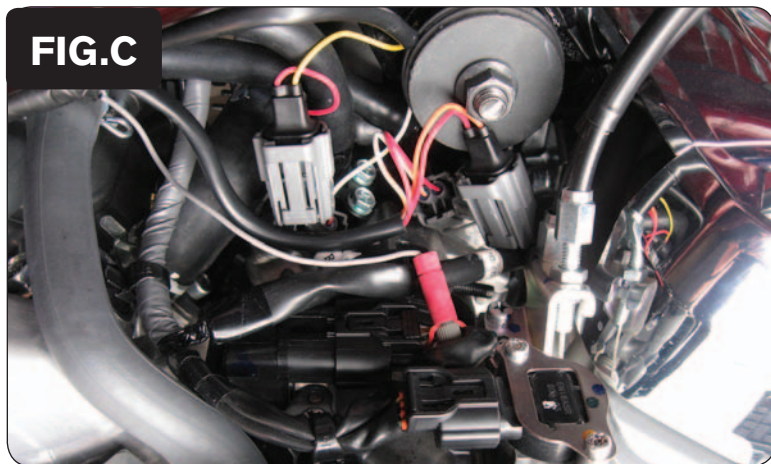

- 7 Connect the PCV harness in-line of the stock wiring harness and injectors (Fig. C).  
*The ORANGE wires from the PCV go to the front cylinder.*



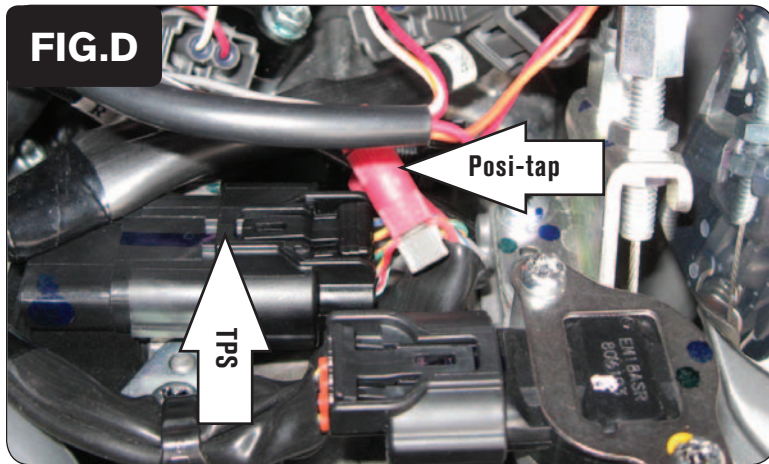

- 8 Using the supplied posi-tap connect the GREY wire of the PCV to the RED/YELLOW wire of the stock Throttle Position Sensor (Fig. D).

*The TPS connector is located near the injector connectors*

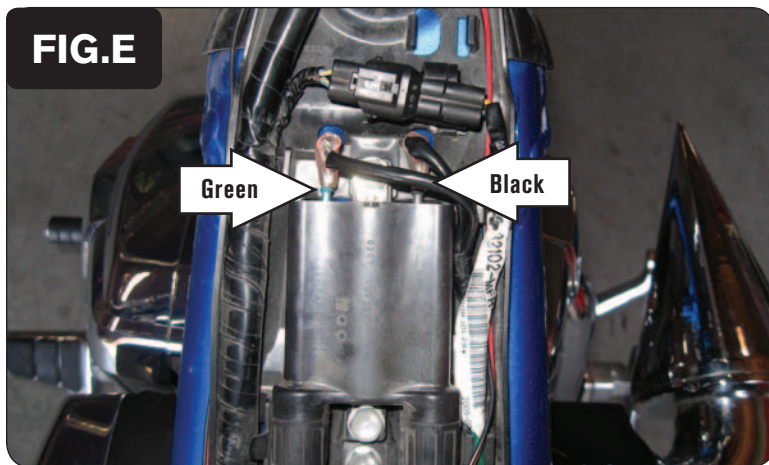
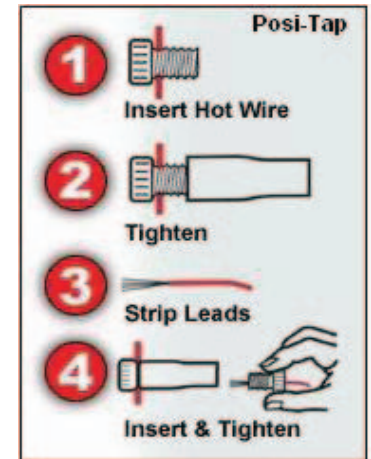

- 9 Locate the Ignition coil under the fuel tank. Unplug the stock wiring harness from the ignition coil paying attention to the wire colors.

*The spade terminals on the ignition coil are marked with a GREEN indicator and a BLACK indicator.*

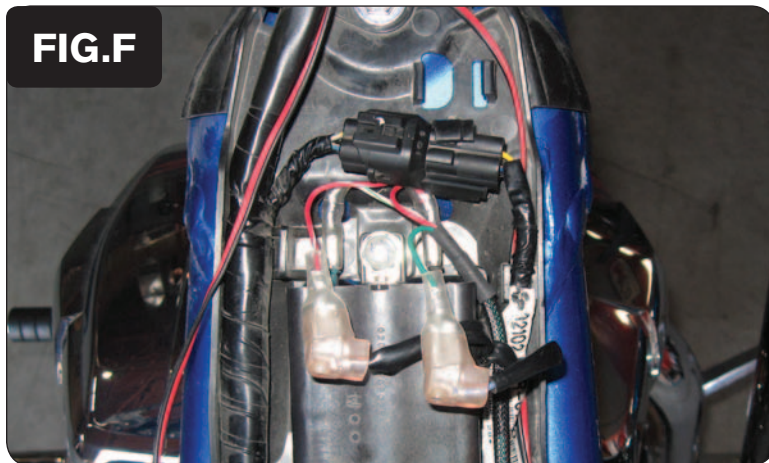

- 10 Plug the PCV in-line of the ignition coil and stock wiring harness.

*The GREEN wires of the PCV go to the GREEN spade terminal.*

*The RED wires of the PCV go to the BLACK terminal*

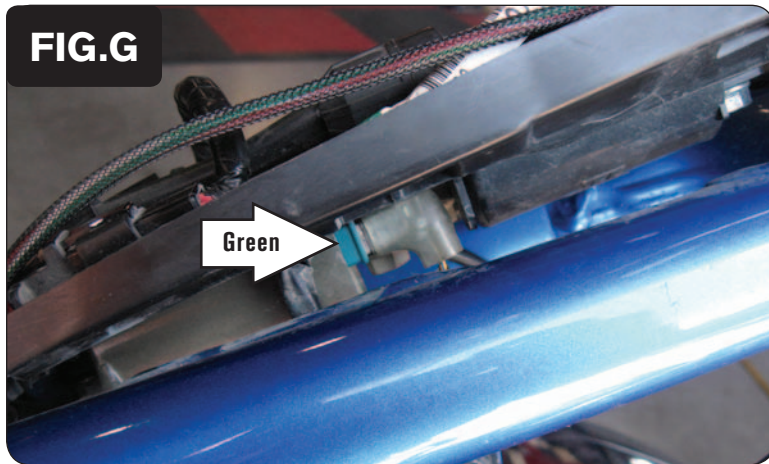

- 11 Locate the Ignition coil on the bottom side of the plastic tray that holds the upper coil from Figure E.
- 12 Unplug the stock wiring harness from the ignition coils GREEN spade terminal (Fig. G).



- 13 Plug the PCV in-line of the ignition coil and stock wiring harness.  
*The BLUE wires of the PCV go to the GREEN spade terminal.*

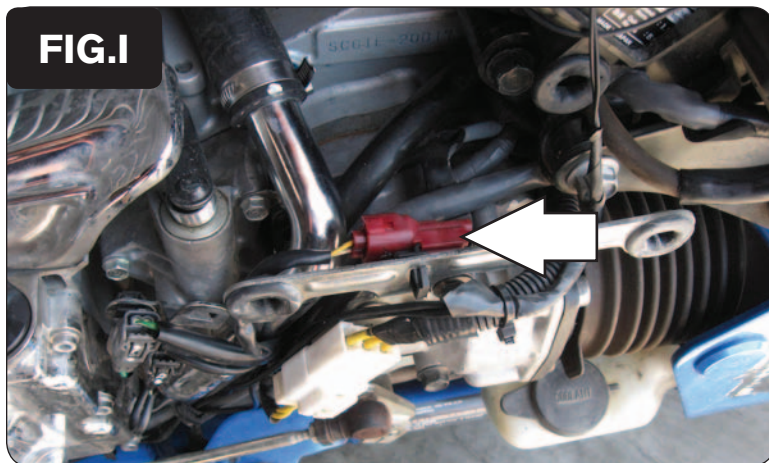

- 14 Locate the RED, 2 pin crank position sensor connector under the left hand cosmetic engine cover on the left side of the bike (Fig. I).
- 15 Unplug the crank position sensor connector.



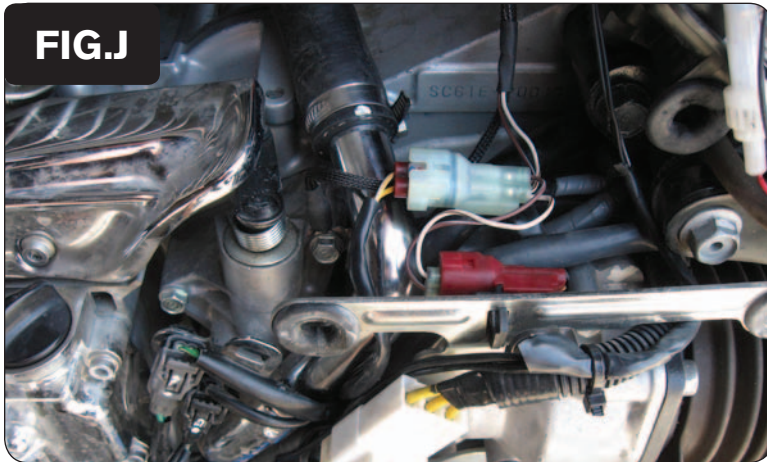

- 16 Plug the connectors from the PCV in-line of the stock crank position sensor and wiring harness (Fig. J).
- 17 Reinstall engine cover making sure the PCV wires do not get damaged.



- 18 Attach the ground wire of the PCV to the negative side of the battery (Fig. K).
- 19 Reinstall bodywork and fuel tank.

**Speed input** - GRN/YEL wire from speed sensor - behind RH mud flap. Need to remove rear fender