



## 50-0190 Kawasaki Z900 2017-18 Frame Slider Installation Instructions

- 1) Remove your OEM left side motor mount bolt. The sliders use the engine mounts shown in the picture on the right.
- 2) Woodcraft recommends using a small amount of Anti-Sieze compound of the threads of the supplied 10x90 socket cap bolt before installation. The frame slider assemblies are the same on both sides of the motorcycle. Take the 10x90 bolt and slide it through the center of the 50-0190RL base. Thread the bolt into the engine by hand until the bolt is snug. Torque the bolt to about 36 ft-lbs.
- 3) Slide the plastic slider over the top of the base and secure in place using the 8mm countersunk bolt provided. The bolt passes first through the non-threaded hole and then screws into the threaded hole on the far side of the base. The plastic is undersized on the far side of the slider to act as a locknut for the bolt.
- 4) Repeat steps 1-3 for the right side of the motorcycle

If you have any questions during installation, please feel free to call.

Woodcraft Technologies, Inc  
978-297-2977  
[www.woodcraft-cfm.com](http://www.woodcraft-cfm.com)

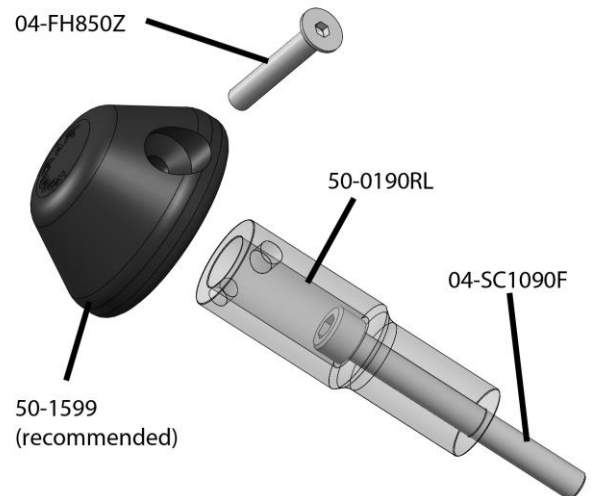

### IMPORTANT

Tighten all fasteners to factory specification or industry standard. FAILURE TO PROPERLY TIGHTEN ALL FASTENERS MAY CAUSE DAMAGE TO THE MOTORCYCLE, LOSS OF CONTROL AND SERIOUS INJURY OR DEATH. DO NOT INSTALL OR USE THIS PRODUCT IF YOU ARE UNABLE TO DO SO IN COMPLIANCE WITH ALL INSTRUCTIONS AND WARNINGS. SEEK THE ASSISTANCE OF A TRAINED PROFESSIONAL TECHNICIAN.