



YOSHIMURA

RESEARCH&DEVELOPMENT OF AMERICA, INC.

5420 DANIELS STREET STE A, CHINO CA., 91710 · (800)634-9166 · (909)628-4722 · FACSIMILE (909)591-2198

www.yoshimura-rd.com

YOSHIMURA PERFORMANCE EXHAUST SYSTEM

SUZUKI

2008-2012

GSX1300R

HAYABUSA

1121086

STAINLESS STEEL R55 FULL SYSTEM WITH SS SLEEVE AND SS ENDCAP



THIS PRODUCT IS DESIGNED FOR USE IN CLOSED COURSE RACING AND IS NOT INTENDED FOR HIGHWAY USE.



NOTE: IN THE STATE OF CALIFORNIA, IT IS ILLEGAL TO MODIFY THE EMISSION CONTROL SYSTEM, WHICH INCLUDES THE FUEL INJECTION OF ANY VEHICLE.

Caution: Exhaust system can be extremely hot. Let motorcycle cool down before beginning installation. Always wear hand and eye protection and take precautionary measures to avoid injury.
Note: Read through all instructions before beginning installation.

Tools Needed:

Metric Socket Set
Ratchet and Extension
Metric Combination Wrench Set
Allen Swivel Socket Set

Metric Allen Wrench Set
Torque Wrench
Yoshimura Spring Puller

Installation Steps:

- 1 Remove left and right fairings.
- 2 Remove lower oil cooler mounting bracket completely from motorcycle (This must be removed to install Yoshimura header with duplex). Also, to ease removal and create more header to radiator clearance, remove lower radiator mount bolt and the bolts connecting the oil cooler to the radiator.
- 3 Remove stock mufflers, stock header, and stock exhaust port gaskets. (Exhaust port gaskets will not be used with Yoshimura exhaust system)

NOTE: Stock oxygen sensor must be removed from stock header before stock header can be removed. Stock oxygen sensor will be reinstalled into Yoshimura header.

- 4 Install Yoshimura manifolds and flanges using the stock header bolts (See Fig. 1 for flange orientation). Leave flange bolts loose to ease Yoshimura header installation. Install exhaust springs onto flanges before header installation. (See Fig. 1)
- 5 Install header from one side of the engine to the other. Slip one tube at a time onto manifolds.

NOTE: Make sure header is fully seated to manifolds. Lightly tapping header legs with a plastic mallet while guiding header legs into manifolds may help installation. Also if header legs w/ duplex (#2 & #3) are difficult to install, lightly tap with plastic mallet to adjust width to match manifolds.
- 6 Loosen two bolts holding stock chassis bracket to chassis. Bolt header to chassis mount using supplied hardware (see Fig. 2 and parts diagram on page 4). Tighten stock chassis bracket.

- 7 Install stock oxygen sensor into Yoshimura header.



Fig. 1



Fig. 2



Fig. 3

- 8 On the right passenger footrest / muffler mount, switch the stock metal insert from the outside of the right rubber muffler mount grommet to the inside of the right rubber muffler mount grommet (see Fig. 3). Remove the left side stock metal insert.
- 9 Install Yoshimura tailpipe and muffler onto the Yoshimura header and secure using the supplied exhaust springs.
- 10 Bolt muffler to the right passenger footrest using the stock muffler mounting hardware (see Fig. 3).
- 11 Torque header bolts to 14 lb-ft (2.0 kg-m).
- 12 Torque chassis and muffler mount bolts to 16.5 lb-ft (2.3 kgf-m).
- 13 Standing at the back of the motorcycle, check for proper alignment of the muffler. Adjust if necessary.

NOTE: To adjust fitment, it may be necessary to rotate the tailpipe or the muffler independently until proper alignment of the muffler is achieved.
- 14 It is recommended that the entire Yoshimura exhaust system be wiped down with rubbing alcohol to remove oil and fingerprints. This will help prevent tarnishing of the finish after the exhaust is heated up.
- 15 Reinstall lower radiator bracket bolt. Reinstall lower oil cooler bracket and bolt.

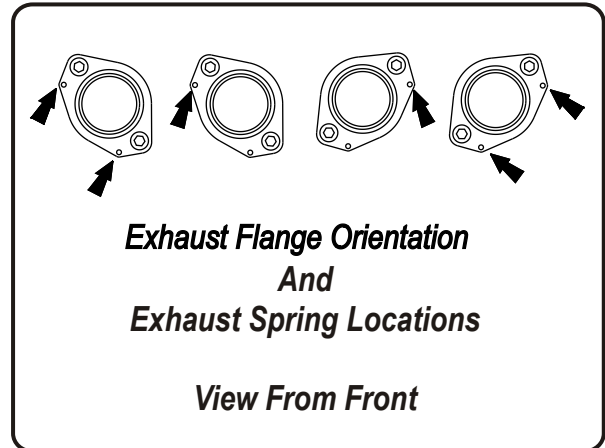

Fig. 1

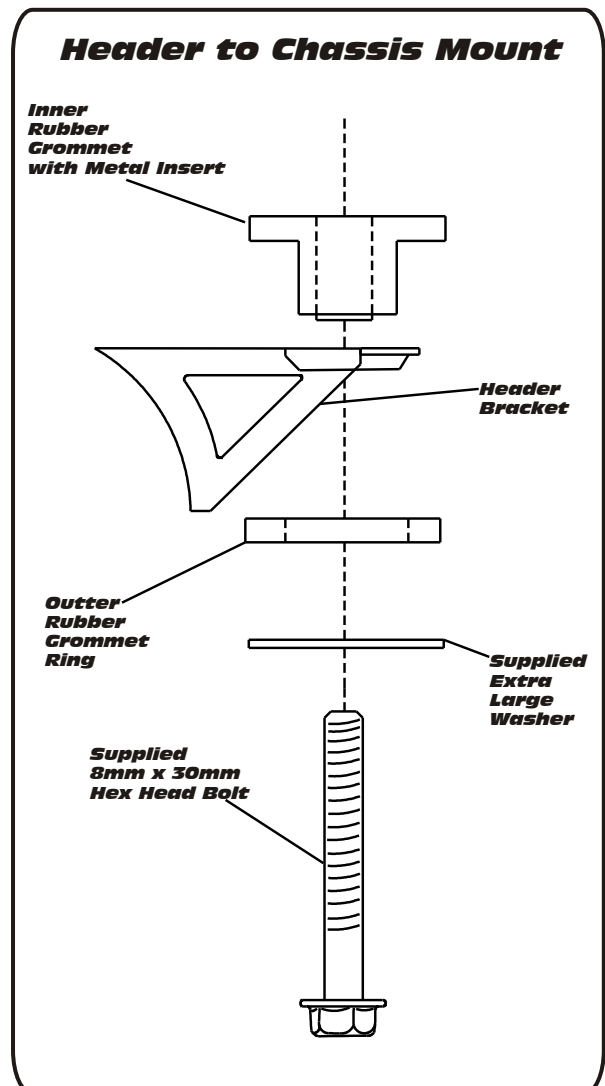

Fig. 2

- 16 Reinstall fairings.
- 17 Check for proper clearance between new exhaust system and motorcycle. (i.e. Swing-arm, body work, etc.) If any problem is found, please carefully follow through the installation steps again. If problem still persists, please call Yoshimura technical department at (800)634-9166 / in CA (909)628-4722.

NOTE: After starting motorcycle, it is normal for new exhaust system and muffler to smoke until oil residue burns off.

NOTE: In order to maximize performance, the Yoshimura R&D header design restricts removal of the oil filter when performing maintenance services. To remove the oil filter, two options are available: 1) remove right side oil cooler hose and remove oil filter from right side of header, 2) remove lower radiator bracket and remove oil filter between #2 and #3 header tubes. If removing the right side radiator hose, after installing the new oil filter make sure to use a new o-ring when reinstalling the hose and torque to 10 N-m (1.0kgf-m, 7.0 lb-ft). If removing the lower radiator bracket, reinstall bracket after new oil filter has been installed and tighten bracket bolts to (1.0kgf-m, 7.0 lb-ft).

NOTE: The Yoshimura header includes an adapter for the O2 sensor bung to be used with the M12X1.25 OEM O2 sensor. In the case that an aftermarket O2 sensor is utilized requiring an M18X1.5 thread pitch, remove the adapter shown in Fig 5 to reveal the M18X1.5 bung.

Right Passenger Footrest

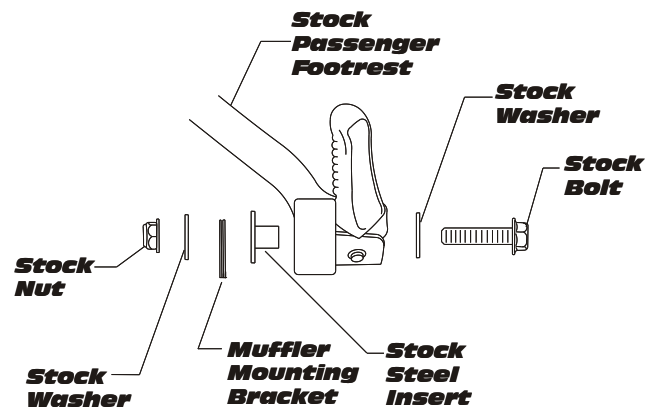

Fig. 3



Fig. 4



Fig. 5

#1121086

S=STOCK

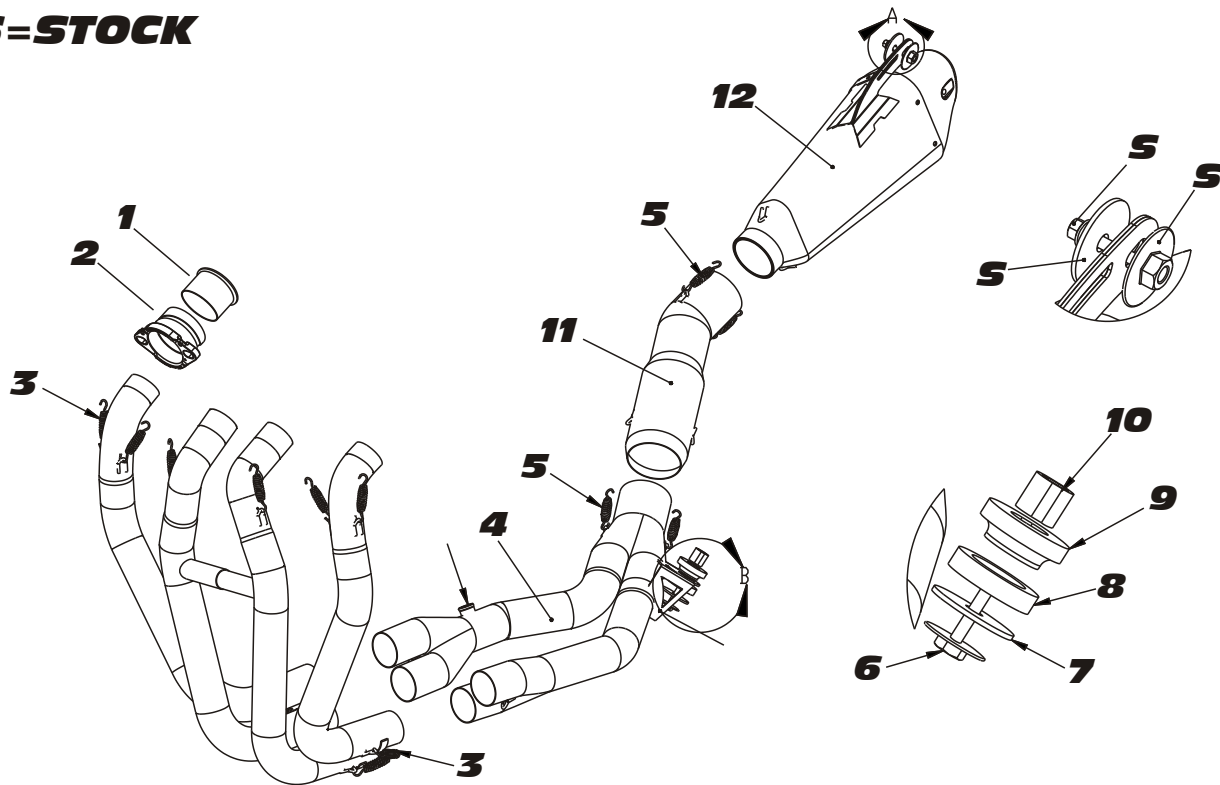

Parts Diagram

NO.	DESCRIPTION	QTY	PART #
1	Yoshimura Exhaust Manifold	4	1117SDM
2	Yoshimura Exhaust Flange	4	YZ117SDR-01
3	Medium Race Spring	10	RACE-SPS-1
4	Yoshimura Header	1	1121-404
5	Small Race Spring	4	RACE-SPX-1
6	8mm x 30mm Hex Head Bolt	1	M8X30H
7	Extra Large Washer	1	8X38WSH
8	Rubber Grommet Outer	1	Z1030
9	Rubber Grommet Inner	1	Z1031
10	Metal Insert for Rubber Grommet	1	Z1031-SP
11	Yoshimura Tailpipe	1	1121-419A
12	Yoshimura R55 Muffler SS Sleeve w/ SS Endcap	1	1121086-RMA
**	Spring Puller Tool	1	ST-200
**	Yoshimura Vinyl Sticker	1	17029