



# YOSHIMURA

RESEARCH&DEVELOPMENT OF AMERICA, INC.

5420 DANIELS STREET STE A, CHINO CA., 91710 · (800)634-9166 · (909)628-4722 · FACSIMILE (909)591-2198

[www.yoshimura-rd.com](http://www.yoshimura-rd.com)

## **YOSHIMURA PERFORMANCE EXHAUST SYSTEM**

**SUZUKI**

**2008-2010**

**GSX-R600**

**GSX-R750**

<b>1170286</b>	R55 SLIP-ON SYSTEM WITH STAINLESS STEEL ENDCAP
<b>1170288</b>	R55 SLIP-ON SYSTEM WITH CARBON FIBER ENDCAP



**THIS PRODUCT IS DESIGNED FOR USE IN CLOSED COURSE RACING AND IS NOT INTENDED FOR HIGHWAY USE.**



NOTE: IN THE STATE OF CALIFORNIA, IT IS ILLEGAL TO MODIFY THE EMISSION CONTROL SYSTEM. WHICH INCLUDES THE CARBURETORS OF ANY VEHICLE.

**Caution:** Exhaust system can be extremely hot. Let motorcycle cool down before beginning installation.

**Note:** Read through all instructions before beginning installation.

## Tools Needed:

Metric Socket Set  
3/8" Ratchet and Extension  
Metric Combination Wrench Set  
Metric Allen Wrench Set  
Torque Wrench

## Installation Steps:

- 1 Remove the stock muffler heatshield (see Fig. 1 for bolt locations).
- 2 Remove the stock muffler and the stock muffler gasket (see Fig. 2 for bolt locations).
- 3 Slide a new stock muffler gasket over the outlet of the stock underbelly muffler (a new stock muffler gasket is not supplied).
- 4 Unbolt the stock right rearset from the stock right adjustable mounting plate (see Fig. 3 for bolt locations).
- 5 Unhook the spring from the rear brake light switch.
- 6 Sandwich the Yoshimura R55 aluminum muffler bracket between the stock right rearset and the stock right adjustable rearset mounting plate using the stock rearset mounting bolts (see Fig. 4).
- 7 Torque the stock right rearset bolts to 2.8 kgf-m (20 lb-ft).
- 8 Reinstall the rear brake light switch spring.
- 9 Slide the supplied exhaust clamp over the inlet of the Yoshimura R55 muffler. Transfer the stock clamp rubber grommet from the stock clamp to the supplied Yoshimura muffler clamp.
- 10 Slide the Yoshimura R55 muffler onto the stock underbelly muffler.

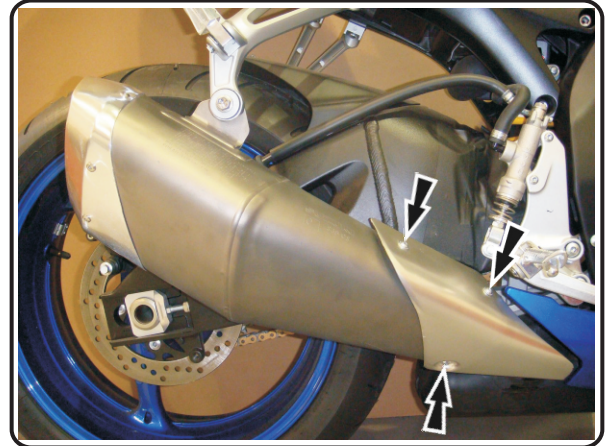

Fig. 1

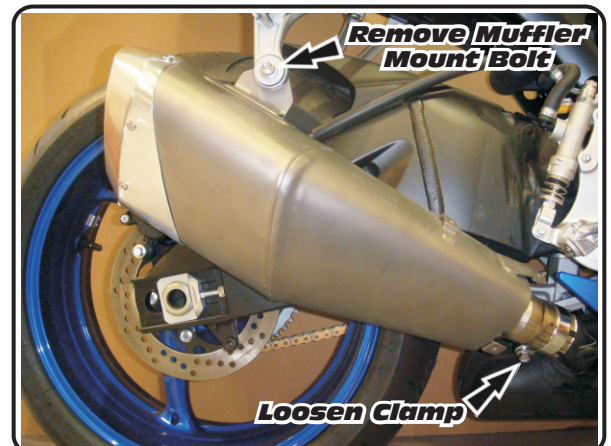

Fig. 2

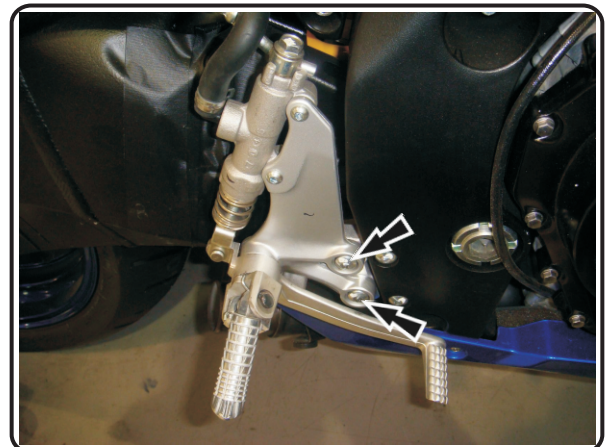
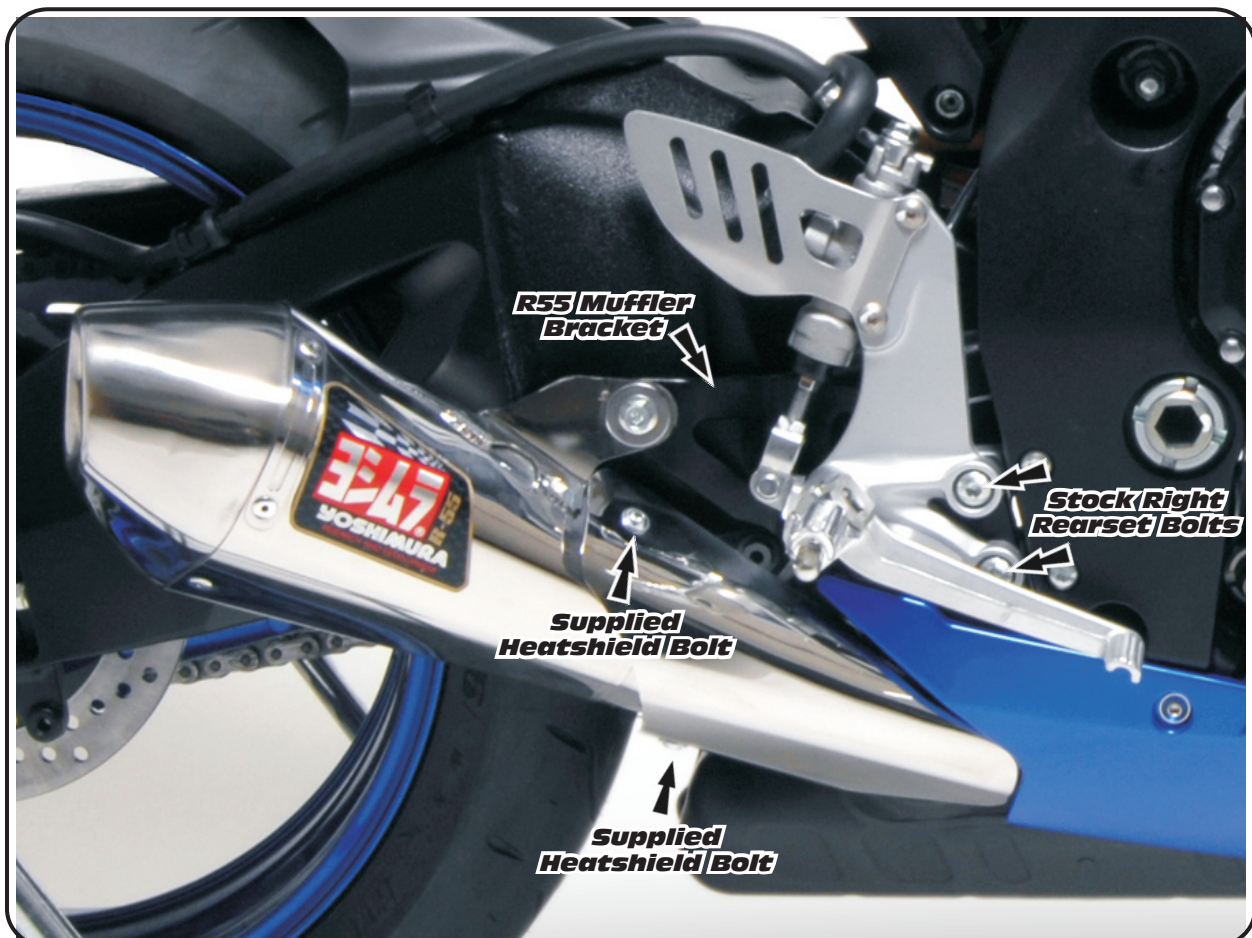

Fig. 3

- 11 *Mount the R55 muffler to the outside of the R55 mounting bracket using the supplied bolt, supplied washer, and supplied spacer nut (see Fig. 4 and the Parts Diagram on page 4).*
- 12 *Torque the muffler mount bolt to 2.3 kgf-m (16.5 lb-ft).*
- 13 *Torque the supplied collector clamp to 1.1 kgf-m (8 lb-ft).*
- 14 *Install the Yoshimura heatshield onto the R55 muffler using the supplied heatshield bolts (see Fig 4).*
- 15 *It is recommended that the muffler and tailpipe be wiped down with rubbing alcohol to remove oil and fingerprints. This will help prevent tarnishing of the finish after the exhaust is heated up.*
- 16 *Check for proper clearance between new exhaust system and motorcycle (i.e. Swing-arm, body work, etc.). If any problem is found, please carefully follow through the installation steps again. If problem still persists, please call Yoshimura technical department at (800)634-9166 / in CA (909)628-4722.*

**NOTE:** After starting motorcycle, it is normal for new exhaust system and muffler to smoke until oil residue burns off.

**Fig. 4**

**#117028(6,8)**

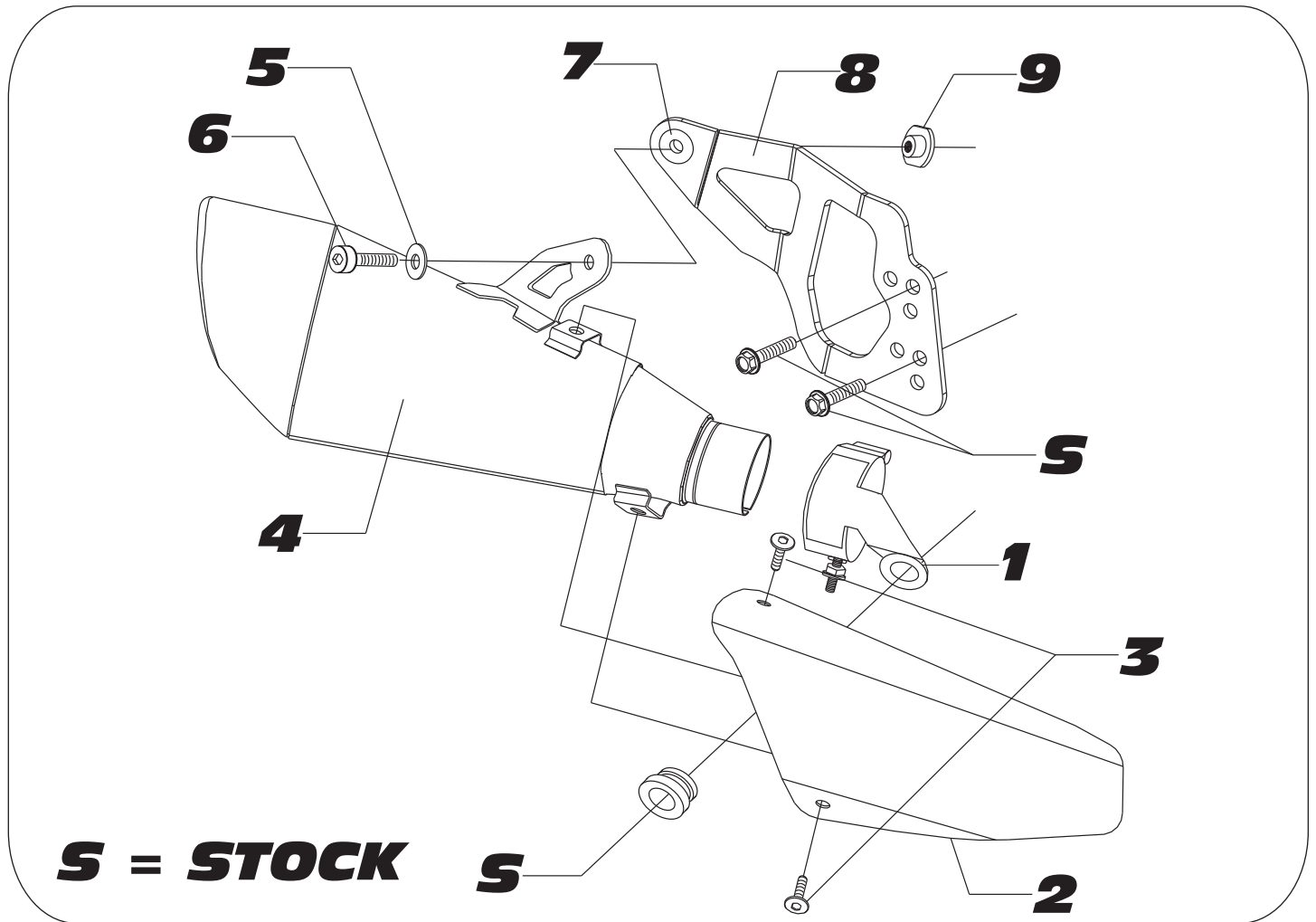

Parts Diagram

<b>NO.</b>	<b>DESCRIPTION</b>	<b>QTY</b>	<b>PART #</b>
1	Exhaust Collector Clamp	1	1170-CLAMP
2	Yoshimura Stainless Steel Heatshield	1	1170285-HS
3	Heatshield Bolts	2	RC116HSB
4	Yoshimura R55 Muffer with Stainless Steel Endcap with Carbon Fiber Endcap	1	1170286-RMA 1170288-RMA
5	Stainless Steel Washer	1	8MMWASHER-SS
6	8mm x 20mm Button Head Bolt	1	M8X20BHS
7	Rubber Grommet	1	Z1022
8	R55 Muffer Mount Bracket	1	1104MBR55-B
9	Aluminum Spacer Nut	1	SPCR-NUT-B
**	Yoshimura Vinyl Sticker	1	17029