



MARAUDER 1600 & MEAN STREAK 1600 BIG SHOTS EXHAUST SYSTEM

Part #18285

CONGRATULATIONS! You have purchased the finest exhaust system available for your motorcycle. Your VANCE & HINES exhaust system is designed for today's rider, a rider who needs maximum performance, great styling and a perfect fitting system. Please follow the installation instructions below and if you have any questions, feel free to call our technical help line (562) 926-5291.

Attention Installer: (if other than owner): Please forward this instruction sheet to the purchaser of this product. These instructions contain valuable information necessary to the end user.



STOCK EXHAUST SYSTEM REMOVAL

1. Remove right side frame cover.
2. Remove frame-like cover from around rectifier, located on left side of motorcycle. This will ease access to the bolt securing the exhaust chamber, in front of the rear wheel.
3. Remove two bolts securing exhaust chamber. One is access one from the left hand side of the motorcycle, the other from the right.
4. Remove exhaust port flange nuts and two piece flanges.
5. Remove bolt securing rear mufflers to the passenger footpeg hanger bracket.
6. Remove complete exhaust system (assistance may be required).

Tools required for installation:

#3 Phillips screwdriver
3/8" Ratchet & Extensions
8, 12, 14mm & 1/2" Sockets
14mm & 1/2" Wrenches
5/16" Nutdriver/Flat blade screwdriver

7. Remove two pairs of rubber grommets used to isolate exhaust chamber from frame.

VANCE & HINES EXHAUST SYSTEM INSTALLATION

1. Check condition of stock exhaust gaskets. Replace if damaged or worn.
2. Using stock mounting bolt, install and tighten supplied mounting bracket (stamped 364-P) in the original mounting bracket location behind passenger footpeg. (*Figure 1*). **Note:** Make sure bracket is mounted in the right direction.
3. Place heat shields on a non-abrasive surface such as a blanket or carpet. Using a felt tip marker, mark the outside surface of front and rear heat shields with the location of the mounting clips welded inside (*Figure 2*).

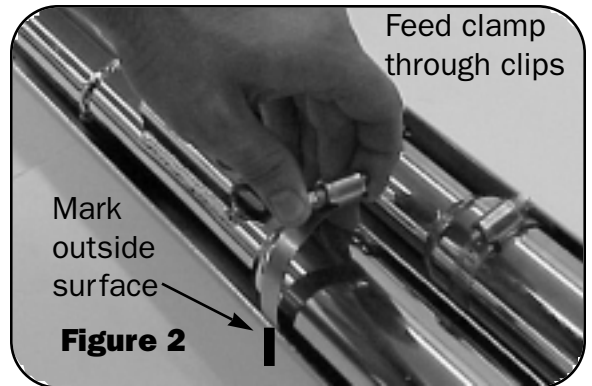
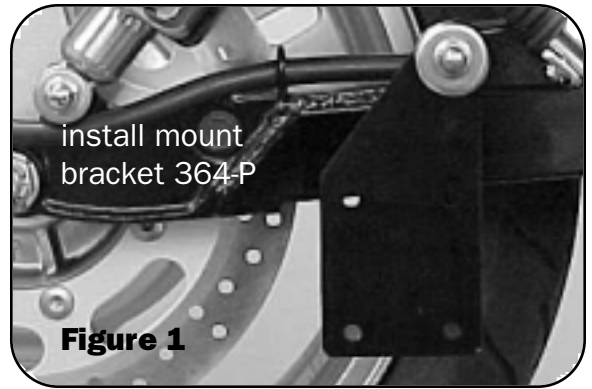

4. Install each heat shield over its respective head pipe (*Figure 3*).



5. Loosely install each hose clamp by feeding tail end of clamp into heat shield clip (*Figure 2*). Take note of clamp screw head direction (*Figure 4*). Screw head should be accessible when system is installed on motorcycle for adjustment purposes. Use #20 hose clamps for head pipe areas and #28 hose clamps for muffler areas.

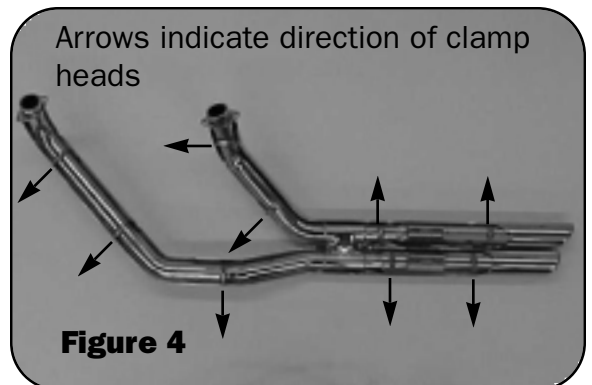

6. Using stock flange nuts, carefully install system into exhaust ports starting with the rear port first. (Assistance may be required). **Note:** Do not tighten yet.

7. Slide dog bone shaped nut plate (supplied) inside each bracket welded to backside of mufflers (*Figure 5*).
8. Attach mufflers to mounting bracket 364-P using 5/16" flange bolts (supplied) engaging dog bone nut plate.
Note: Do not tighten yet.
9. Tighten exhaust port flange nuts securing head pipes to cylinder heads.
10. Tighten 5/16" flange bolts securing mufflers to mounting bracket.

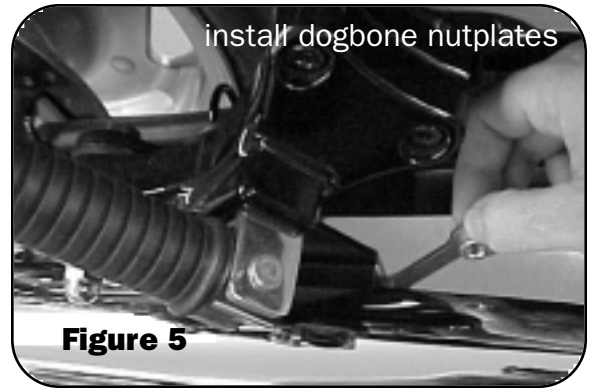

11. Align ends so that slash cuts are even (*Figure 6*).
12. Tighten all hose clamps securing heat shields.
13. Reinstall right side cover and frame-like cover around rectifier.



14. Remove oil and fingerprints from chrome using a soft cloth and non abrasive cleaner before starting engine.
15. **Important: All hardware must be properly tightened before starting motorcycle.**

RE-JETTING INSTRUCTIONS

Re-jetting the carburetors will result in realizing the "full" potential of this performance exhaust system. Vance & Hines offers jet kits for most applications. For fuel injected models, we recommend the use of an adjustable fuel management system.

PLEASE NOTE: Every effort is made for Vance & Hines Exhaust Systems to provide improved cornering clearance. However, due to design and space limitations on some motorcycle models, (center stand, oil filter, oil pan etc.) ground and cornering clearance may not be improved and in some cases may be reduced. Be sure to follow proper installation instructions.

PACKING LIST (All parts actual size)

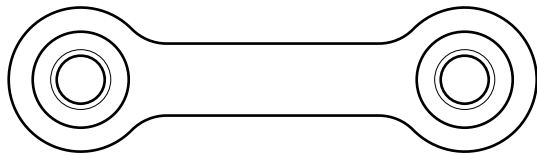

Nutplate x 2

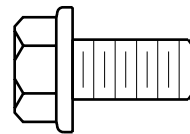

5/16" Flange bolt x 4

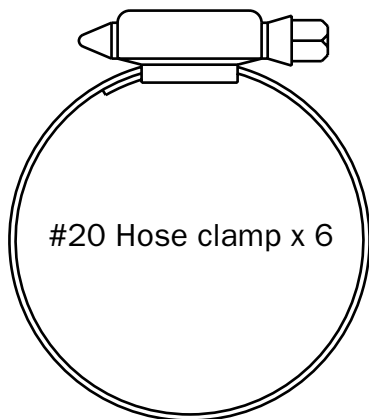

#20 Hose clamp x 6

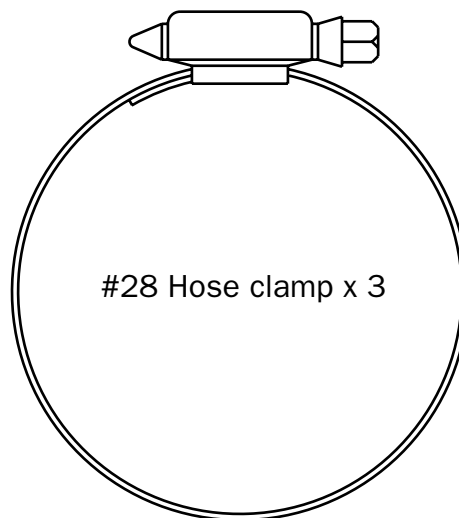

#28 Hose clamp x 3

HELPFUL HINTS TO AVOID DISCOLORATION OF EXHAUST PIPES

1. Follow owner's manual instructions regarding use of the choke (starter enricher). If left on longer than recommended, discoloration may be accelerated.
2. Avoid long periods of idling.
3. Intake leaks can cause engine to run lean and overheat, thus turning the pipes blue.
4. Make sure there are no exhaust leaks at the junction of the exhaust pipe and cylinder head.
5. When installing a new set of chrome pipes, make sure your hands are clean and free of oil. After installation, thoroughly clean pipes with a cleaning solvent that will leave no residue (glass cleaner, alcohol, ammonia, etc.) before starting the motorcycle.

WARNING!

VANCE & HINES DOES NOT WARRANTY ANY CHROME PRODUCTS AGAINST DISCOLORATION.

For information about other Vance and Hines products visit our web site at www.vanceandhines.com